

## **ANNEXE 2**

**VERSION ANGLAISE DES OUTILS CAPACITÉS MOTRICES ET  
ENVIRONNEMENT DOMICILIAIRE**



## ENGLISH VERSION BASIC MOVEMENTS-MOTOR CAPACITIES

### WARM-UP: BASIC MOVEMENTS

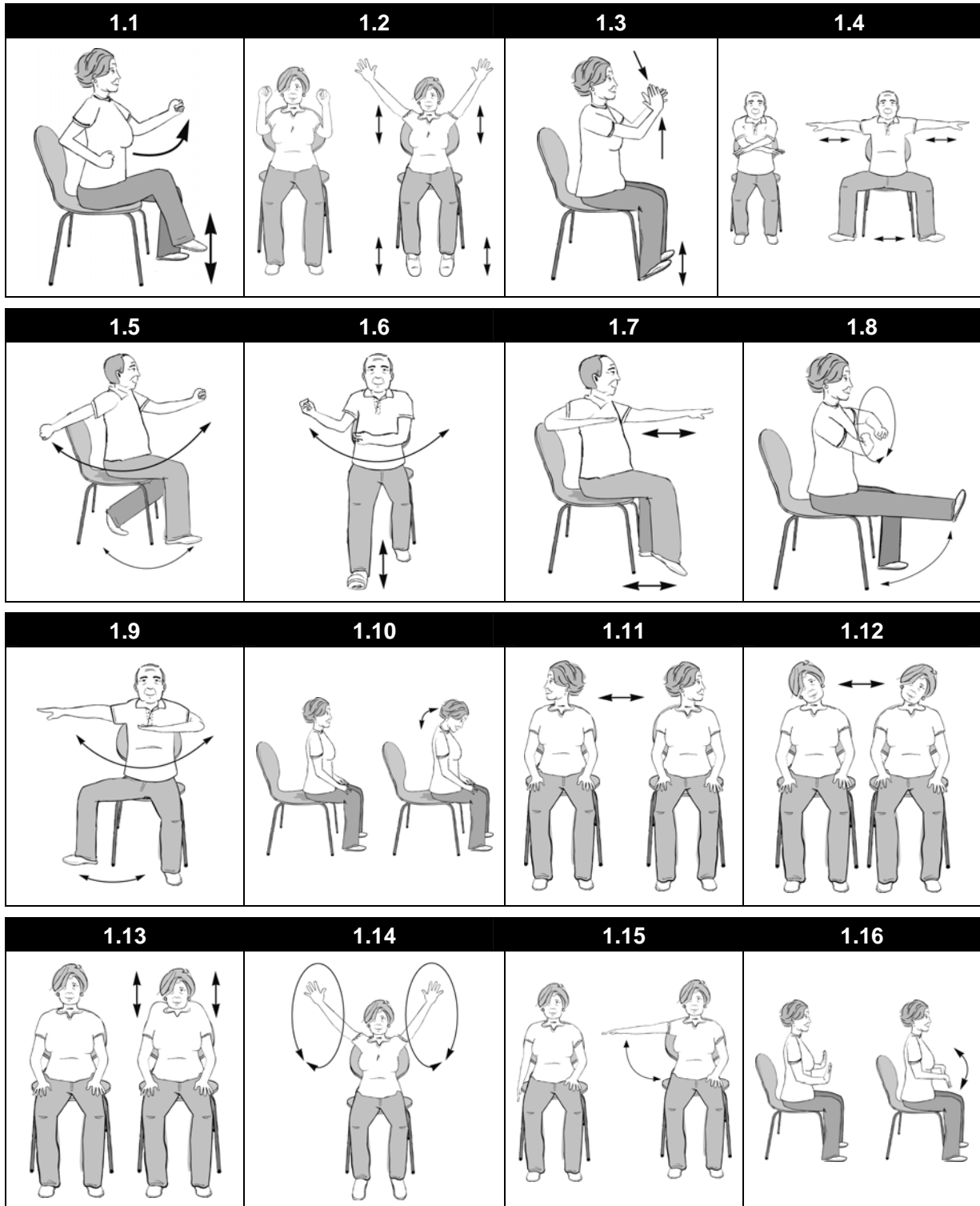

### WARM-UP: BASIC MOVEMENTS

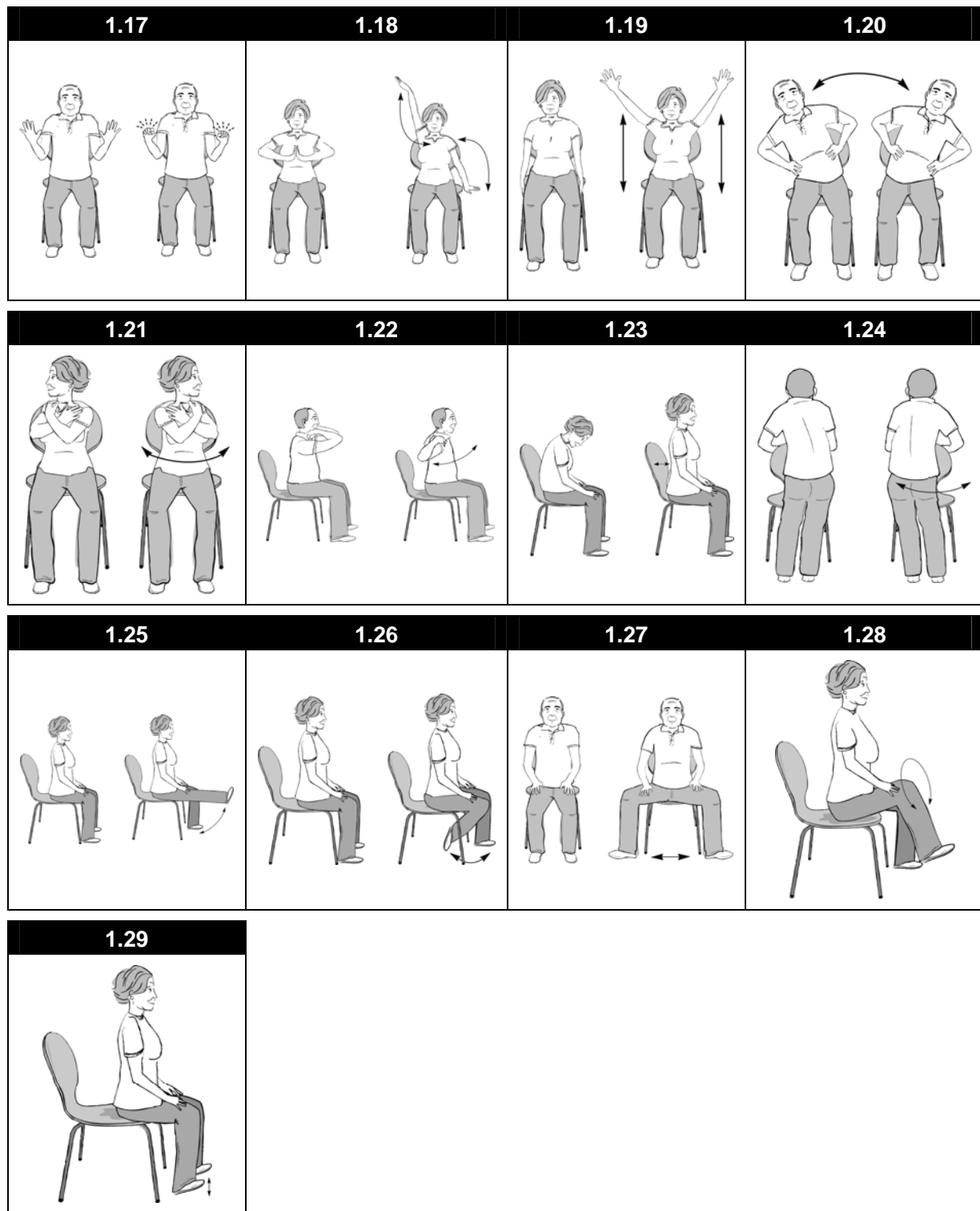

## MOVEMENT 1.1

### Warm-up for:

Arms and legs.

### Starting position

- seated in the centre of the chair, back straight;
- arms against your sides, elbows at 90° angle, hands in a fist;
- feet flat on the floor, hip-width apart.

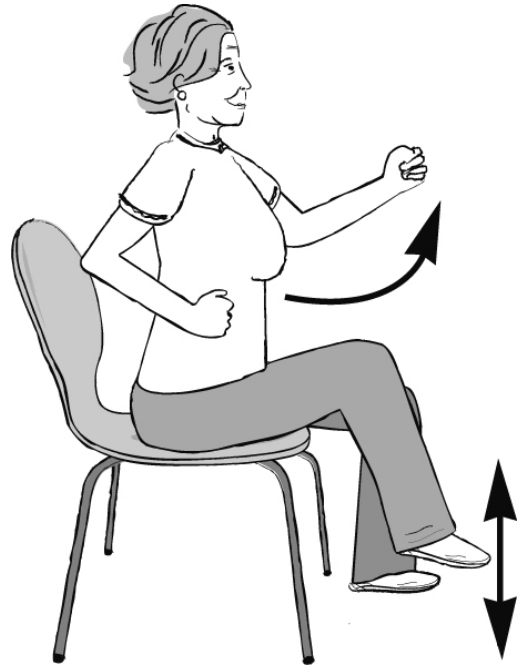

### Exercise

Walk in place swinging arms forward and backward, using opposite arm to leg.

### Repetition(s)

30 seconds.

---

---

---

---

---

---

---

---

## MOVEMENT 1.2

### Warm-up for:

Arms and legs.

### Starting position

- seated in the centre of the chair, back straight;
- elbows bent so that your hands are above shoulder level, in a fist;
- feet flat on the floor, hip-width apart.

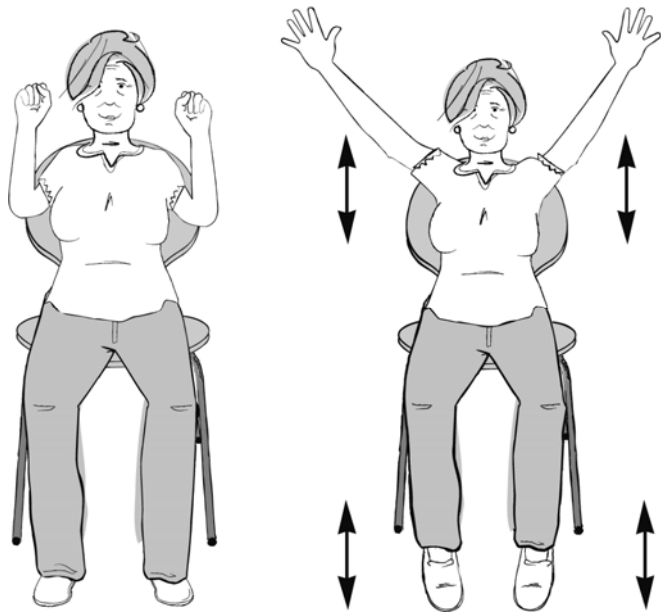

### Exercise

Raise heels and arms simultaneously. When arms are fully extended above your shoulders, open and stretch fingers. Return to starting position.

### Repetition(s)

30 seconds.

---

---

---

---

---

---

---

---

### MOVEMENT 1.3

#### Warm-up for:

Arms and legs.

#### Starting position

- seated in the centre of the chair, back straight;
- hands joined in front of your chest;
- feet flat on the floor, hip-width apart.



#### Exercise

Raise your toes and then return to starting position. Clap your hands in various directions each time you raise your toes.

#### Repetition(s)

30 seconds.

---

---

---

---

---

---

---

---

---

---

## MOVEMENT 1.4

### Warm-up for:

Arms and legs.

### Starting position

- seated in the centre of the chair, back straight;
- arms crossed and extended in front of you at chest level;
- feet flat on the floor, hip-width apart.

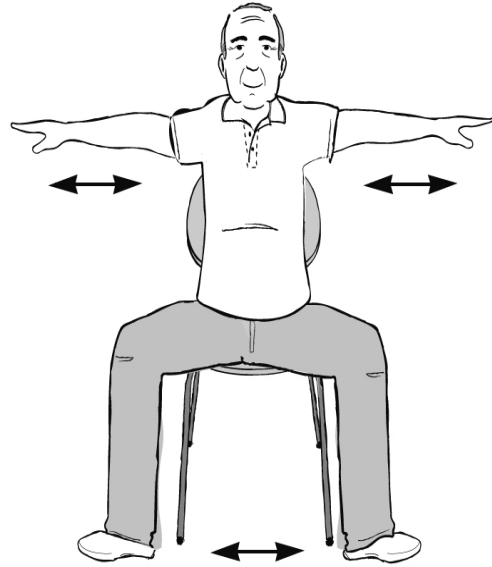

### Exercise

Open your legs and put your feet down wider apart than your hips, then come back to starting position. At the same time, open your arms out to the sides and come back to starting position.

### Repetition(s)

30 seconds.

---

---

---

---

---

---

---

---



## MOVEMENT 1.5

### Warm-up for:

Arms and legs.

### Starting position

- seated in the centre of the chair, back straight;
- arms fully extended at chest level, left arm in front and right arm behind;
- feet flat on the floor, hip-width apart.

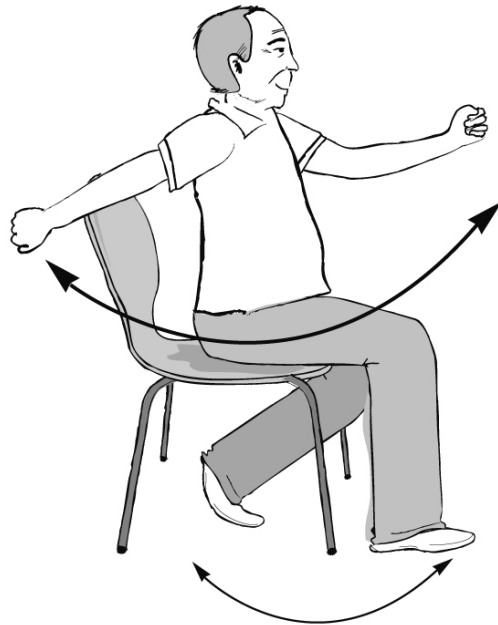

### Exercise

Bring your right foot and left arm forward while drawing right arm and left foot back under the chair. Reverse arm and foot movement, as in cross-country skiing.

### Repetition(s)

30 seconds.

---

---

---

---

---

---

---

---

## MOVEMENT 1.6

### Warm-up for:

Arms and legs.

### Starting position

- seated in the centre of the chair, back straight;
- arms down by your sides;
- feet flat on the floor, hip-width apart.

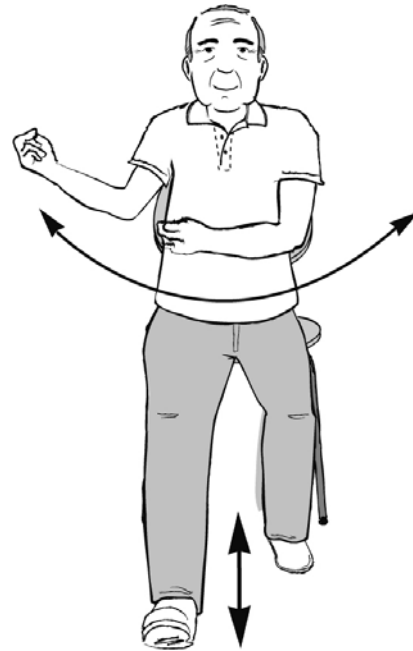

### Exercise

Bring right foot forward and touch floor with heel while clicking your fingers to your right side. Bring right foot back to starting position and do the same movement on the left side.

### Repetition(s)

30 seconds.

---

---

---

---

---

---

---

---

---

---

## MOVEMENT 1.7

### Warm-up for:

Arms and legs.

### Starting position

- seated in the centre of the chair, back straight;
- arms stretched out in front at shoulder level;
- feet flat on the floor, hip-width apart.

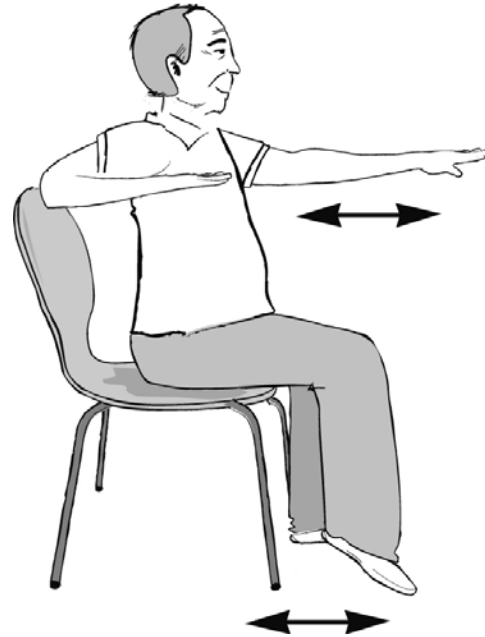

### Exercise

Bring right foot out in front and touch the floor with your toes while extending left arm forward and right arm back. Bring right foot back to starting position and do the same movement on the other side.

### Repetition(s)

30 seconds.

---

---

---

---

---

---

---

---

## MOVEMENT 1.8

### Warm-up for:

Arms and legs.

### Starting position

- seated in the centre of the chair, back straight;
- elbows at 90° angle in front of your chest;
- feet flat on the floor, hip-width apart.



### Exercise

Stretch and raise your right leg so that toes are pointed upward. Return to starting position and do the same movement with the left leg. Roll your forearms in one direction while stretching each leg and then roll forearms in the other direction while returning to starting position.

### Repetition(s)

30 seconds.

---

---

---

---

---

---

---

---

## MOVEMENT 1.9

### Warm-up for:

Arms and legs.

### Starting position

- seated in the centre of the chair, back straight;
- arms extended to one side at shoulder level;
- feet flat on the floor, hip-width apart.

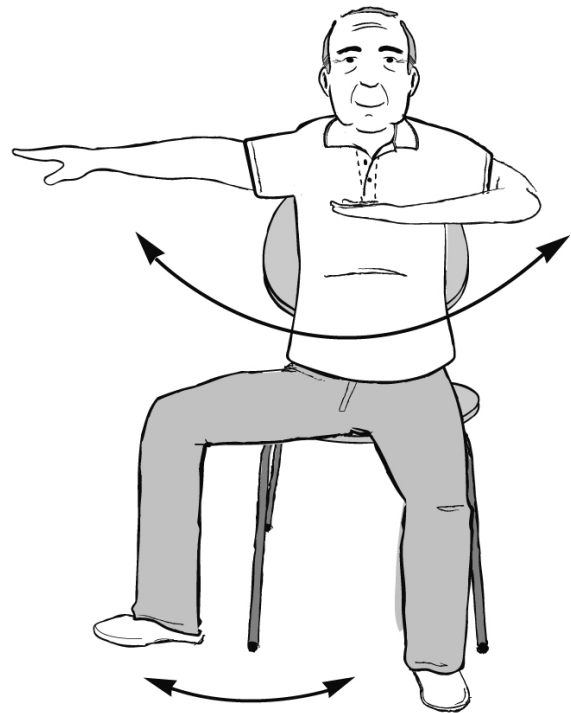

### Exercise

Open right leg, turning right foot outward on the floor, then return to starting position and do the same movement with left leg. Reverse the arm movement each time you open your leg.

### Repetition(s)

30 seconds.

---

---

---

---

---

---

---

---

## MOVEMENT 1.10

### Warm-up for:

Neck.

### Starting position

- seated in the centre of the chair, back straight;
- hands resting on thighs;
- feet flat on the floor, hip-width apart.

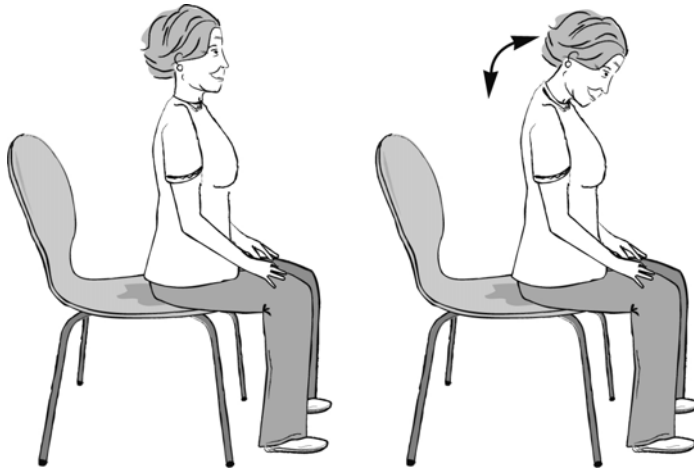

---

### Safety tip

Avoid over-extending the neck backward.

---

### Exercise

Drop your chin to your chest and return to starting position.

### Repetition(s)

5.

---

---

---

---

---

---

---

---

---

---

## MOVEMENT 1.11

### Warm-up for:

Neck.

### Starting position

- seated in the centre of the chair, back straight:
- hands resting on thighs;
- feet flat on the floor, hip-width apart.

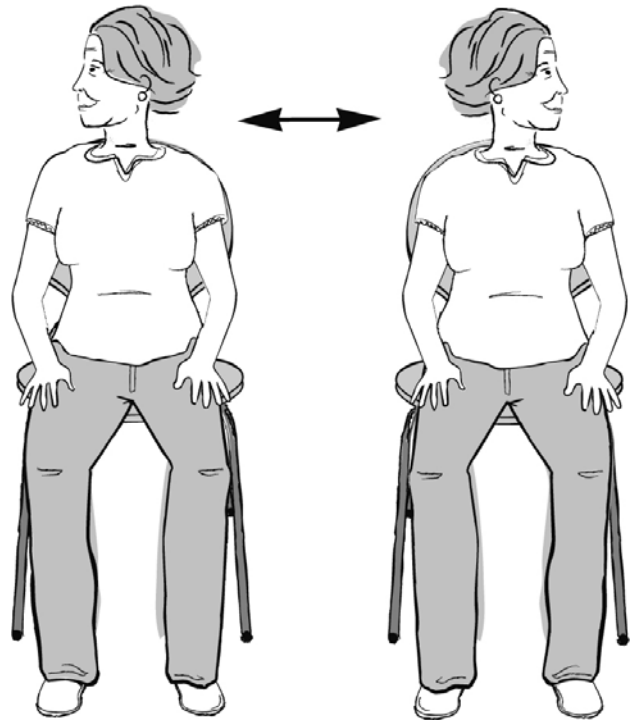

### Exercise

Turn head slowly to the right and then to the left.

### Repetition(s)

5 on each side, alternating.

---

---

---

---

---

---

---

---

## MOVEMENT 1.12

### Warm-up for:

Neck.

### Starting position

- seated in the centre of the chair, back straight;
- hands resting on thighs;
- feet flat on the floor, hip-width apart.

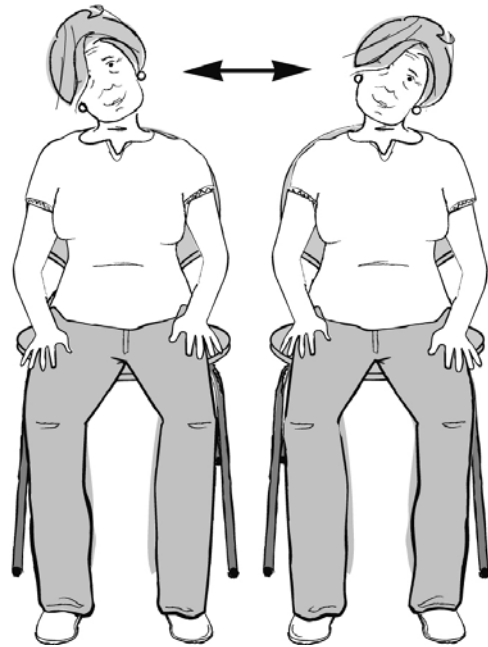

### Exercise

Bend neck to the right, dropping the ear toward the right shoulder, then repeat movement toward the left.

### Repetition(s)

5 on each side, alternating.

---

---

---

---

---

---

---

---

---

---



### MOVEMENT 1.13

#### Warm-up for:

Upper back and shoulders.

#### Starting position

- seated in the centre of the chair, back straight;
- hands resting on thighs;
- feet flat on the floor, hip-width apart.

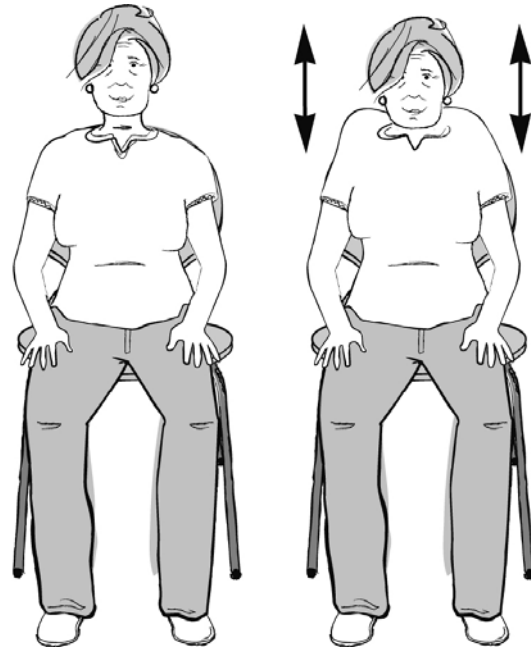

#### Exercise

Raise shoulders to your ears and then return to starting position.

#### Repetition(s)

5.

---

---

---

---

---

---

---

---

## MOVEMENT 1.14

### Warm-up for:

Shoulders, arms, torso.

### Starting position

- seated in the centre of the chair, back straight;
- arms by your sides;
- feet flat on the floor, hip-width apart.

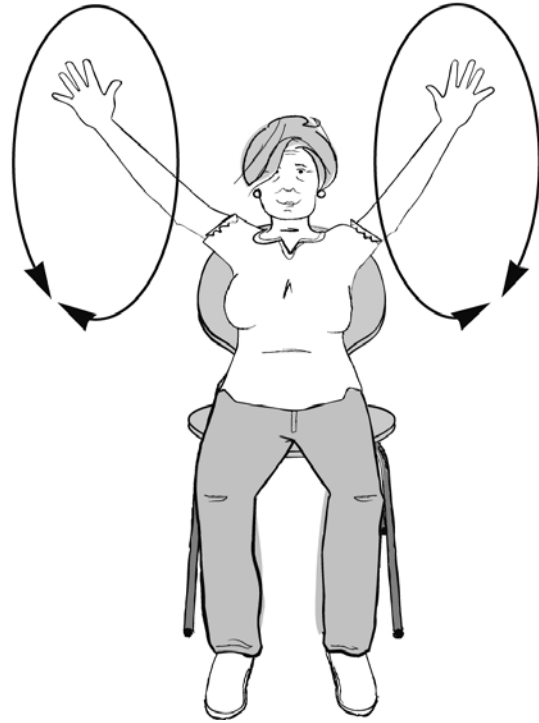

### Exercise

Make big circles forward and backward with your arms.

### Repetition(s)

5 in each direction.

---

---

---

---

---

---

---

---

## MOVEMENT 1.15

### Warm-up for:

Shoulders.

### Starting position

- seated in the centre of the chair, back straight;
- arms by your sides, left hand on your thigh and right hand stretched down toward the floor;
- feet flat on the floor, hip-width apart.

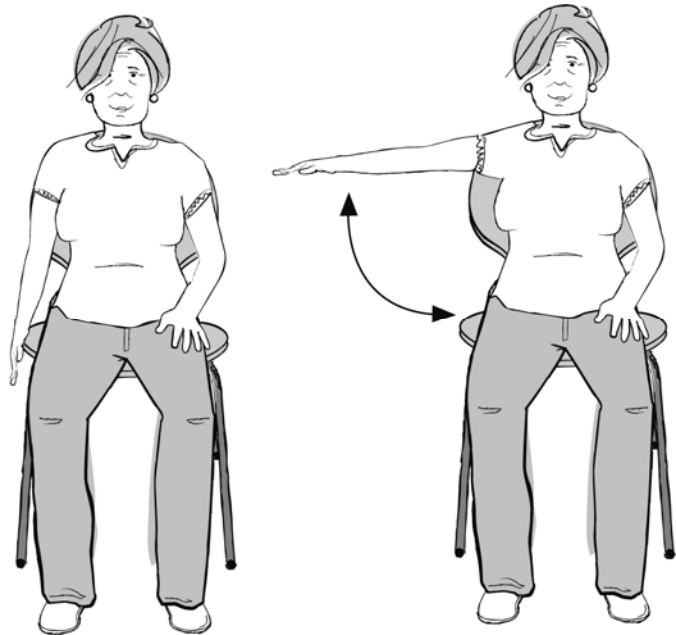

### Exercise

Raise right arm to the side until it is level with your shoulder and return to starting position. Repeat movement with left arm.

### Repetition(s)

5 on each side, alternating.

---

---

---

---

---

---

---

## MOVEMENT 1.16

### Warm-up for:

Wrists.

### Starting position

- seated in the centre of the chair, back straight;
- arms at 90° angle, forearms snug against your sides and parallel to thighs, palms turned out;
- feet flat on the floor, hip-width apart.

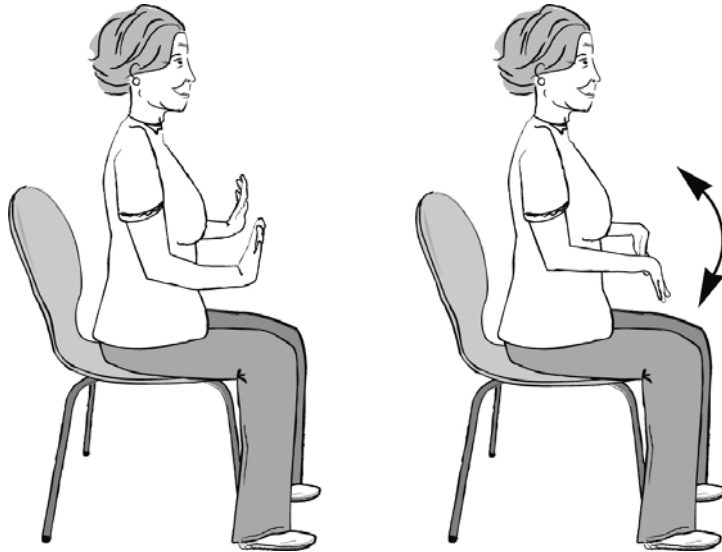

### Exercise

Flex and then extend wrists.

### Repetition(s)

5.

---

---

---

---

---

---

---

## MOVEMENT 1.17

### Warm-up for:

Hands.

### Starting position

- seated in the centre of the chair, back straight;
- arms at 90° angle, palms out and fingers pointing up;
- feet flat on the floor, hip-width apart.



---

### Safety tip

Persons with arthritis should be careful with this exercise

---

### Exercise

Open and close hands.

### Repetition(s)

5.

---

---

---

---

---

---

---

---

---

---

## MOVEMENT 1.18

### Warm-up for:

Torso, arms.

### Starting position

- seated in the centre of the chair, back straight;
- hands joined in front of your chest;
- feet flat on the floor, hip-width apart.



### Exercise

Raise right arm over your head, flexing your wrist so that the palm is turned toward the ceiling and extend the left arm toward the floor, palm facing down. Return to starting position and repeat the movement on the opposite side.

### Repetition(s)

5 on each side, alternating.

---

---

---

---

---

---

---

---

## MOVEMENT 1.19

### Warm-up for:

Arms, shoulders, torso.

### Starting position

- seated in the centre of the chair, back straight;
- arms by your sides;
- feet flat on the floor, hip-width apart.

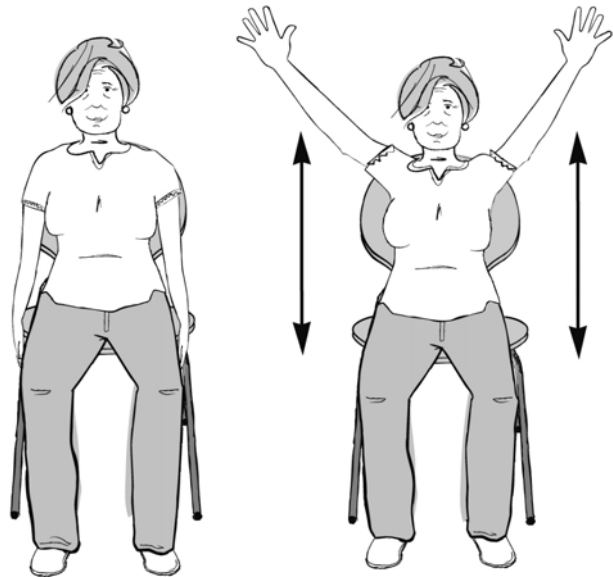

### Exercise

Raise arms above your head, palms forward, then return to starting position.

### Repetition(s)

5.

---

---

---

---

---

---

---

---

## MOVEMENT 1.20

### Warm-up for:

Torso.

### Starting position

- seated in the centre of the chair, back straight;
- hands on waist;
- feet flat on the floor, hip-width apart.

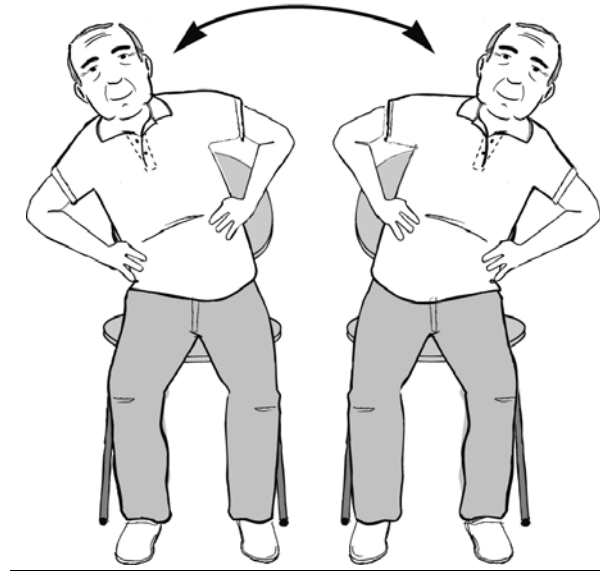

### Safety tip

To avoid losing your balance, make sure your feet remain flat on the floor and your buttocks firmly on the seat of your chair.

---

### Exercise

Bend your torso first to the right and then to the left.

### Repetition(s)

5 on each side, alternating.

---

---

---

---

---

---

---

---

---

---



## MOVEMENT 1.21

### Warm-up for:

Torso.

### Starting position

- seated in the centre of the chair, back straight;
- arms crossed on your chest;
- feet flat on the floor, hip-width apart.

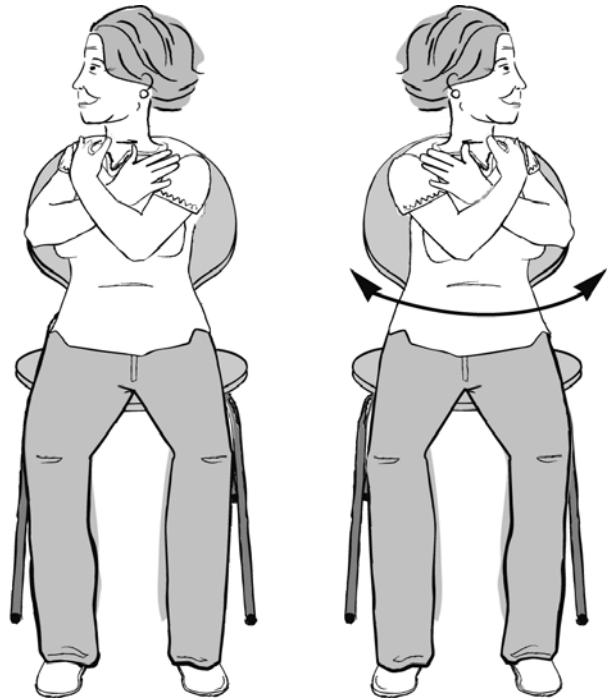

### Exercise

Turn torso to the right and then to the left, keeping your chin tucked in.

### Repetition(s)

5 on each side, alternating.

---

---

---

---

---

---

---

---

## MOVEMENT 1.22

### Warm-up for:

Back, chest.

### Starting position

- seated in the centre of the chair, back straight;
- hands resting on your shoulders, elbows pointing forward at shoulder level;
- feet flat on the floor, hip-width apart.

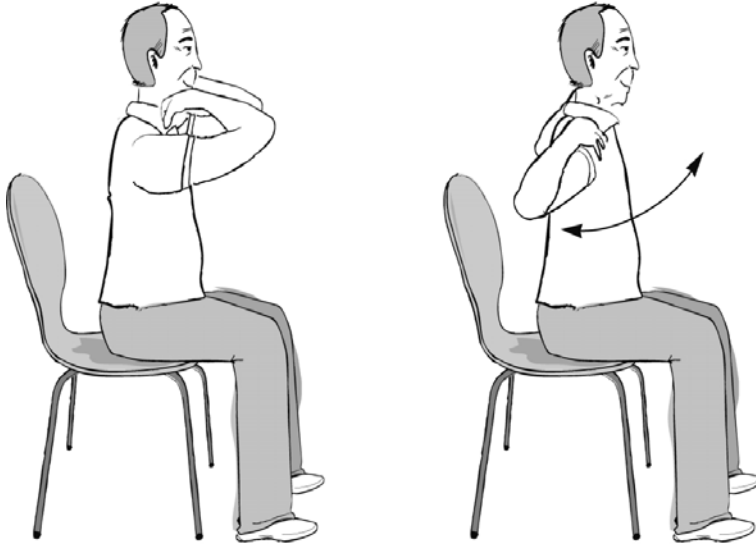

### Exercise

Touch elbows in front of you, then push them back.

### Repetition(s)

5.

---

---

---

---

---

---

---

## MOVEMENT 1.23

### Warm-up for:

Torso.

### Starting position

- seated. back straight, lower back against chair back;
- hands resting on thighs;
- feet flat on the floor, hip-width apart.

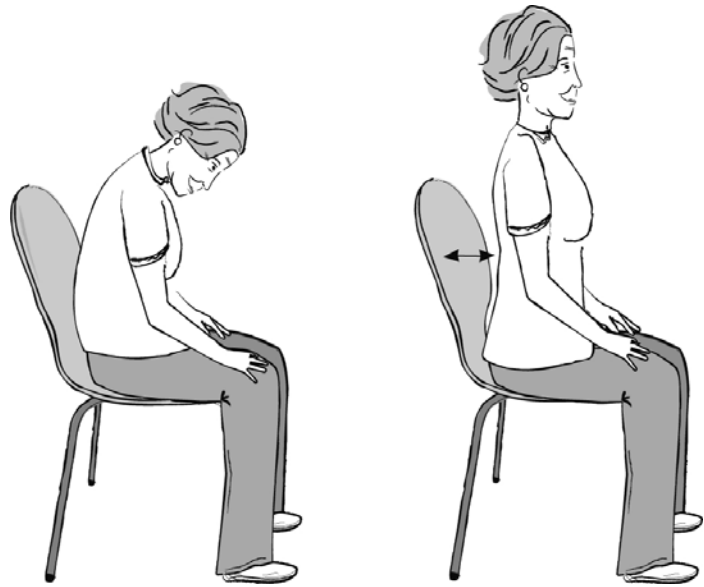

### Exercise

Press lower back against the back of the chair, bending head forward until chin is resting on your chest. Then arch lower back and puff chest out.

### Repetition(s)

5.

---

---

---

---

---

---

---

---

## MOVEMENT 1.24

### Warm-up for:

Pelvis.

### Starting position

- standing behind a chair;
- hands on back of chair;
- feet flat on the floor, hip-width apart.

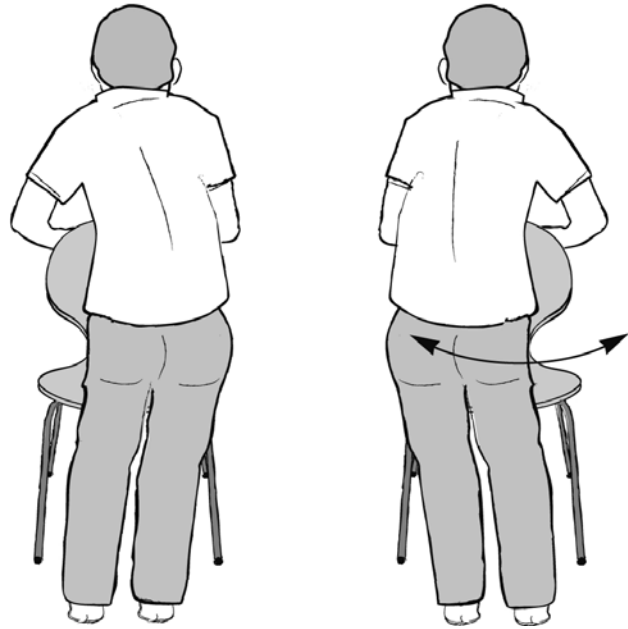

### Exercise

Push your hips to the right and then to the left.

### Repetition(s)

5 on each side, alternating.

---

---

---

---

---

---

---

---

---

---

## MOVEMENT 1.25

### Warm-up for:

Thighs.

### Starting position

- seated in the centre of the chair, back straight;
- hands resting on thighs;
- feet flat on the floor, hip-width apart.

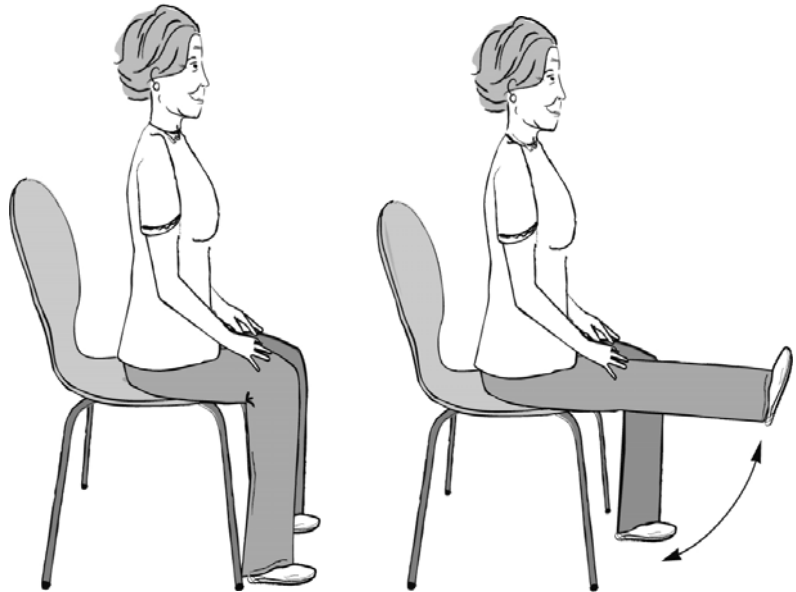

### Exercise

Raise one leg straight out, come back to starting position and repeat with other leg.

### Repetition(s)

5 on each side, alternating.

---

---

---

---

---

---

---

---

## MOVEMENT 1.26

### Warm-up for:

Thighs.

### Starting position

- seated forward on the chair, back straight;
- hands resting on thighs;
- feet flat on the floor, hip-width apart.

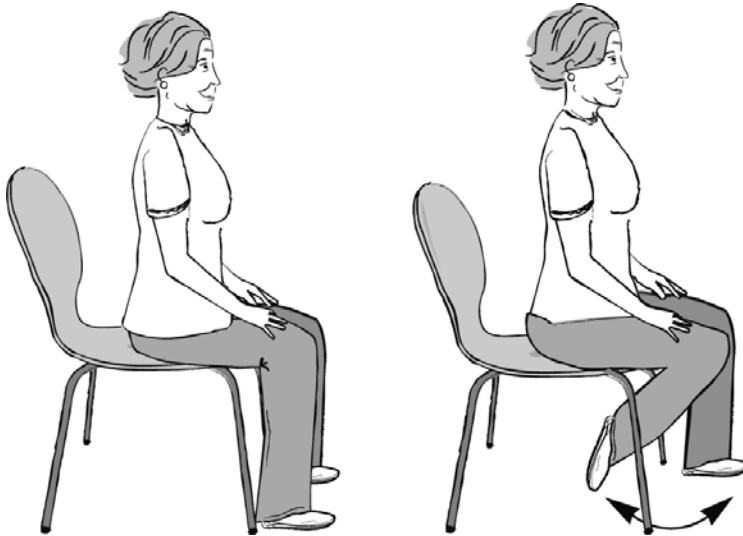

### Exercise

Flex knee, bringing leg under the chair, heel up toward the seat, without touching the floor with your toes. Return to starting position and repeat the movement with the other leg.

### Repetition(s)

5 on each side, alternating.

---

---

---

---

---

---

---

---



## MOVEMENT 1.27

### Warm-up for:

Hips.

### Starting position

- seated in the centre of the chair, back straight;
- hands resting on thighs;
- feet flat on the floor, hip-width apart.

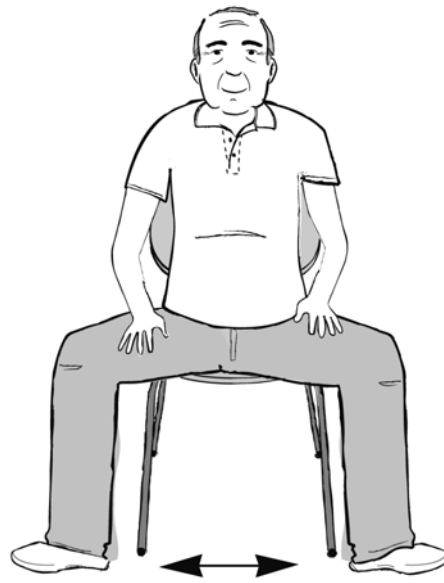

### Exercise

Keeping knees at 90° angle, open one leg placing foot close to chair leg, then do the same with the other leg. Bring legs back to starting position one at a time.

### Repetition(s)

5.

---

---

---

---

---

---

---



## MOVEMENT 1.28

### Warm-up for:

Hips

### Starting position

- seated in the centre of the chair, back straight;
- hands resting on thighs;
- feet flat on the floor, hip-width apart.



### Exercise

Raise one thigh and draw imaginary circles with your knee, clockwise and then counterclockwise. Return to starting position and do the same with the other leg.

### Repetition(s)

5 on each side, alternating.

---

---

---

---

---

---

---

---

## MOVEMENT 1.29

### Warm-up for:

Ankles.

### Starting position

- seated in the centre of the chair, back straight;
- hands resting on thighs;
- feet flat on the floor, hip-width apart.



### Exercise

Raise toes and balls of your feet, keeping heels on the floor, then return to starting position.

### Repetition(s)

5.

---

---

---

---

---

---

---

---

---

## ENGLISH VERSION BASIC MOVEMENTS-MOTOR CAPACITIES

### STATIC BALANCE: BASIC MOVEMENTS

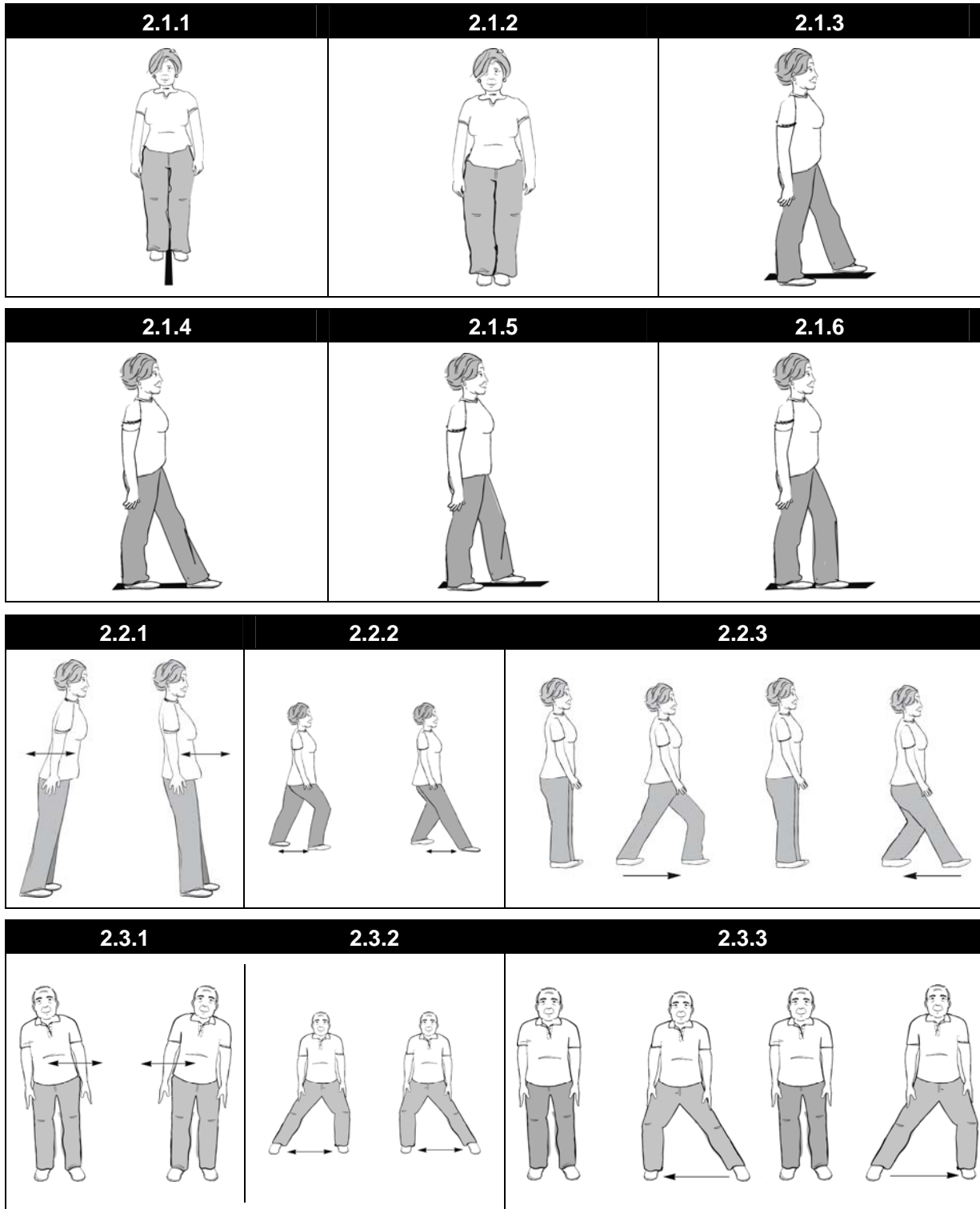

## STATIC BALANCE: BASIC MOVEMENTS

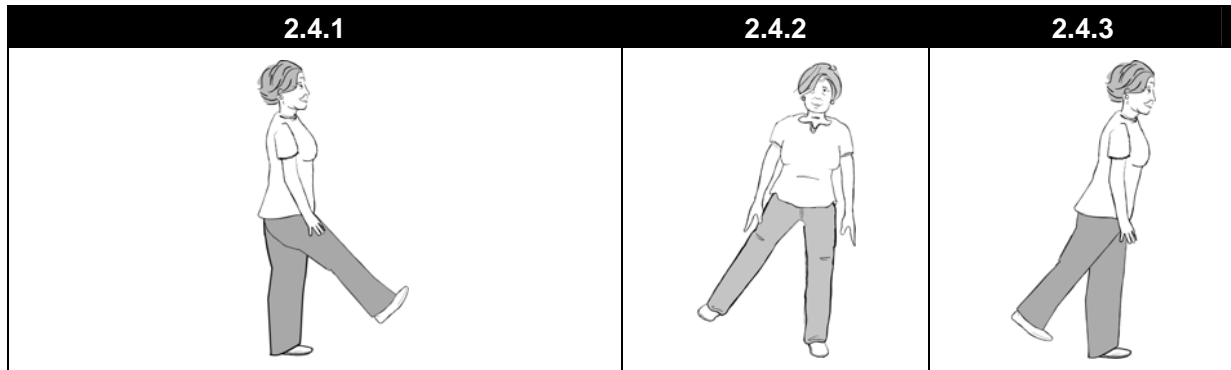

## MOVEMENT 2.1.1

### Objective

To improve static balance with a reduced support-base.

### Starting position

- standing, back straight;
- arms straight down by your sides;
- strip of adhesive tape on the floor;
- feet on either side of the tape.

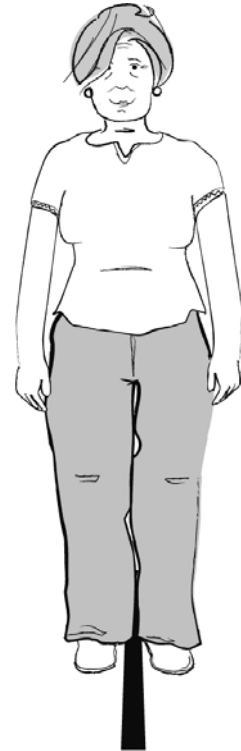

### Equipment

Strip of adhesive tape about 1 metre long.

### Exercise

Hold the position.

### Hold for

5 to 10 seconds.

---

---

---

---

---

---

---

---

## MOVEMENT 2.1.2

### Objective

To improve static balance with a reduced support-base.

### Starting position

- standing, back straight;
- arms straight down by your sides;
- feet together.

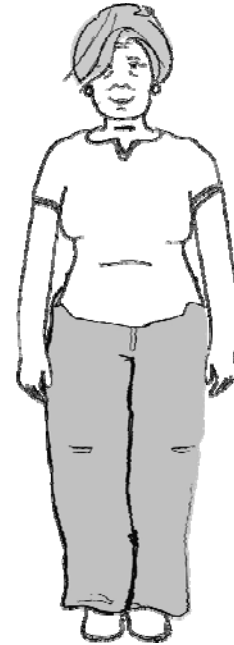

### Exercise

Hold the position.

### Hold for

5 to 10 seconds.

---

---

---

---

---

---

---

---

---

---

## MOVEMENT 2.1.3

### Objective

To improve static balance with a reduced support-base.

### Starting position

- standing, back straight;
- arms straight down by your sides;
- strip of adhesive tape on the floor;
- feet on either side of the tape, left leg in front, with a space of about 1 foot between feet.

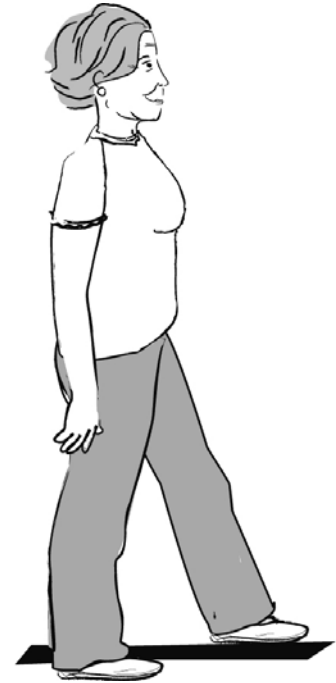

### Equipment

Strip of adhesive tape about 1 metre long.

### Exercise

Hold the position.

### Hold for

5 to 10 seconds per position.

- 1st position: left leg in front of right leg;
- 2nd position: right leg in front of left leg.

---

---

---

---

## MOVEMENT 2.1.4

### Objective

To improve static balance with a reduced support-base.

### Starting position

- standing, back straight;
- arms straight down by your sides;
- strip of adhesive tape on the floor;
- standing on the tape, left leg in front with a space of about one foot between your feet.

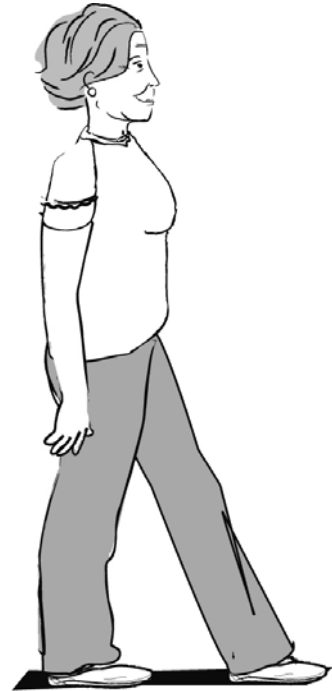

### Equipment

Strip of adhesive tape about 1 metre long.

### Exercise

Hold the position.

### Hold for

5 to 10 seconds per position.

- 1st position: left leg in front of right leg;
- 2nd position: right leg in front of left leg.

---

---

---

---



## MOVEMENT 2.1.5

### Objective

To improve static balance with a reduced support-base.

### Starting position

- standing, back straight;
- arms straight down by your sides;
- strip of adhesive tape on the floor;
- feet on either side of the tape, left leg forward, heel of left foot level with toes of right foot.

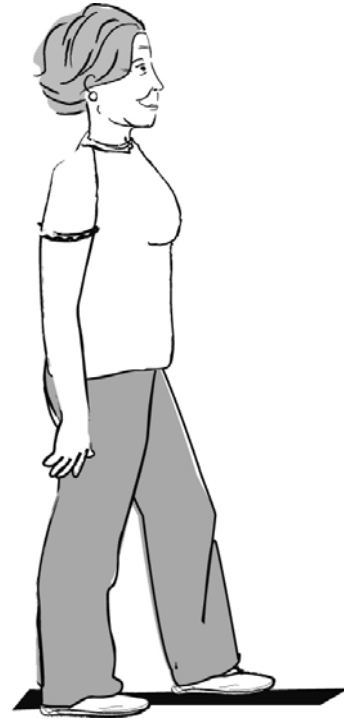

### Equipment

Strip of adhesive tape about 1 metre long.

### Exercise

Hold the position.

### Hold for

5 to 10 seconds per position.

- 1st position: left leg in front of right leg;
- 2nd position: right leg in front of left leg.

---

---

---

---

## MOVEMENT 2.1.6

### Objective

To improve static balance with a reduced support-base.

### Starting position

- standing, back straight;
- arms straight down by your sides;
- strip of adhesive tape on the floor;
- standing on the tape, left leg in front, heel of left foot close to toes of right foot.

### Equipment

Strip of adhesive tape about 1 metre long.

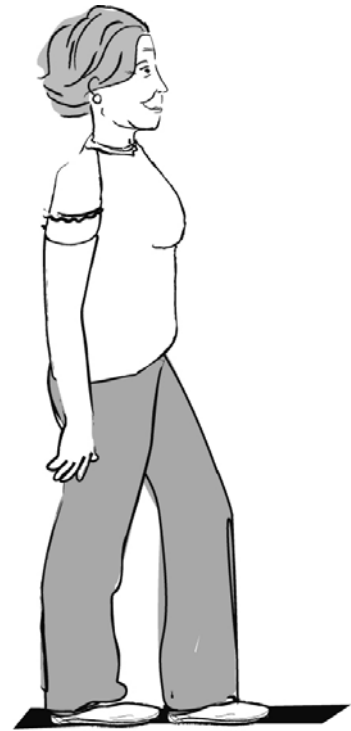

### Exercise

Hold the position.

### Hold for

5 to 10 seconds per position.

- 1st position: left leg in front of right leg;
- 2nd position: right leg in front of left leg.

---

---

---

---

## MOVEMENT 2.2.1

### Objectives

To improve static balance when transferring weight forward or backward. Helps achieve better control of limits of stability range.

### Starting position

- standing, back straight;
- arms straight down by your sides;
- feet hip-width apart.

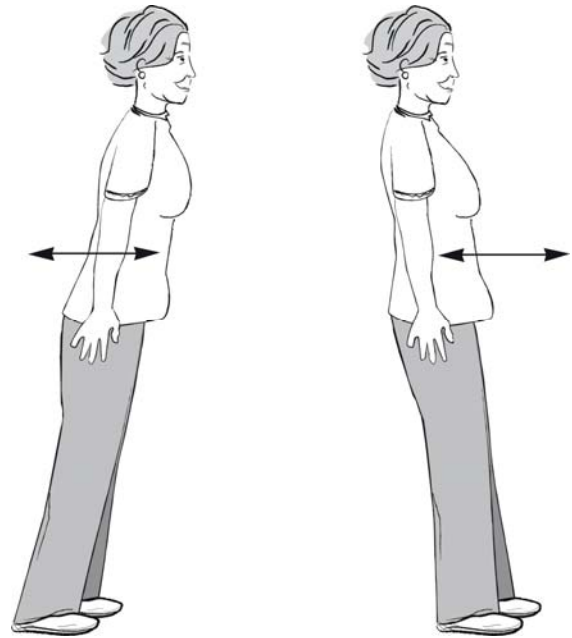

### Exercise

Transfer your entire body weight forward then backward, as far as possible within your range of balance.

### Repetition(s)

5.

---

---

---

---

---

---

---

---

## MOVEMENT 2.2.2

### Objectives

To improve static balance when transferring weight forward or backward. Helps achieve better control of limits of stability range.

### Starting position

- standing, back straight;
- arms straight down by your sides;
- feet hip-width apart, right leg forward, space of about one foot between the feet.

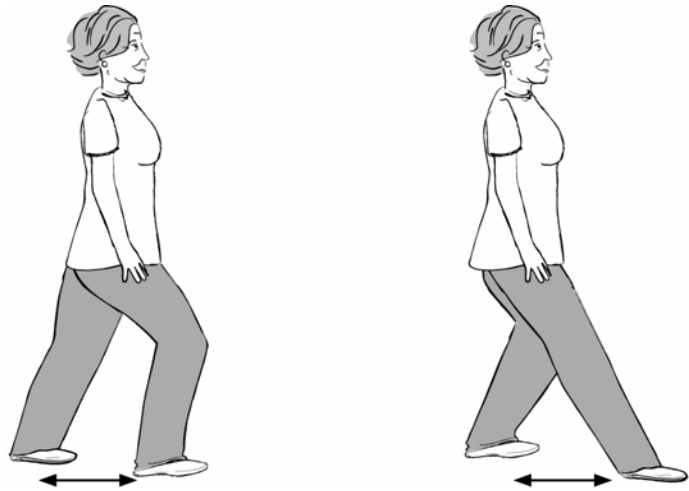

### Exercise

Transfer your entire body weight forward bending right knee, and then backward bending left knee. Alternate.

### Repetition(s)

5 per position.

- 1st position: right leg in front of left leg;
- 2nd position: left leg in front of right leg.

---

---

---

---

---

---

### MOVEMENT 2.2.3

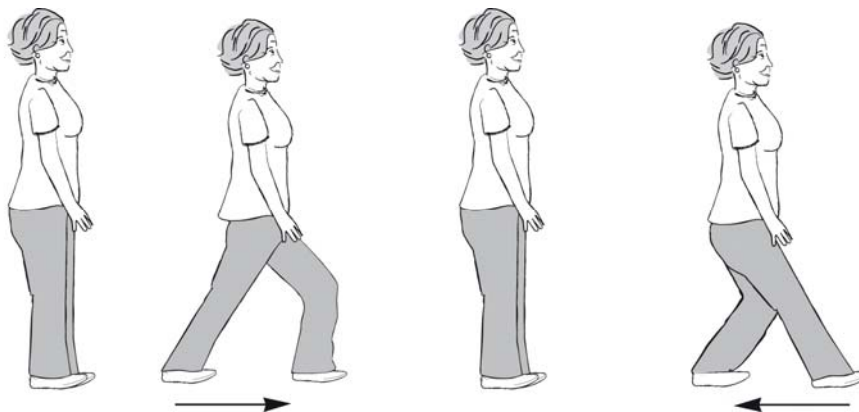

#### Objectives

To improve static balance when transferring weight forward or backward. Helps achieve better control of limits of stability range.

#### Starting position

- standing, back straight;
- arms straight down by your sides;
- feet hip-width apart.

#### Exercise

Step forward with left leg, transferring weight to this leg by bending left knee. Return to starting position and step backward with left leg, transferring weight to this leg by bending left knee.

#### Repetition(s)

5 per movement.

- 1st movement: step with left leg;
  - 2nd movement: step with right leg.
- 
-

## MOVEMENT 2.3.1

### Objectives

To improve static balance when transferring weight to the right and then to the left. Helps achieve better control of limits of stability range.

### Starting position

- standing, back straight;
- arms straight down by your sides;
- feet hip-width apart.

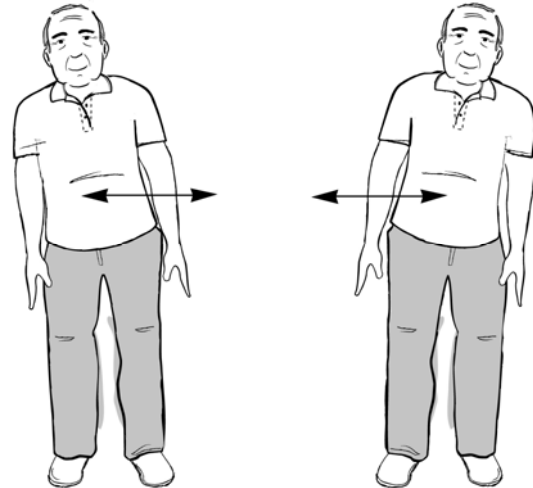

### Exercise

Transfer your entire body weight toward the right and then toward the left, alternately, within your range of balance.

### Repetition(s)

5.

---

---

---

---

---

---

---

---

---

---

## MOVEMENT 2.3.2

### Objectives

To improve static balance when transferring weight to the right and then to the left. Helps achieve better control of limits of stability range.

### Starting position

- standing, back straight;
- arms straight down by your sides;
- feet wider apart than your hips.

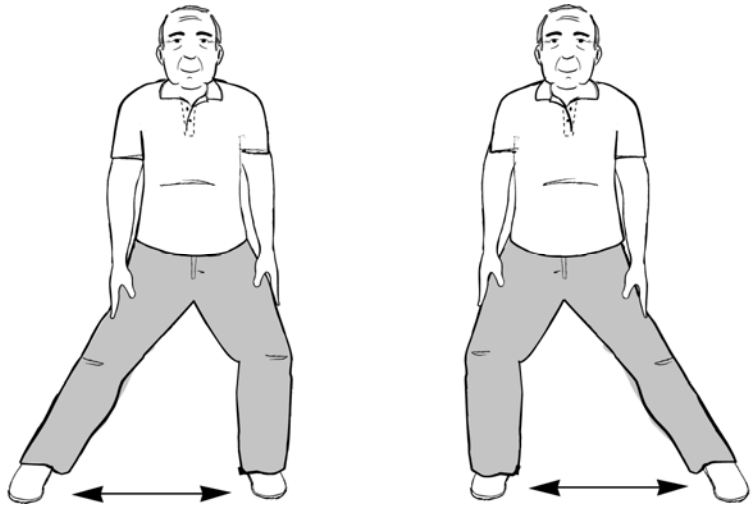

### Exercise

Transfer your entire body weight left bending left knee and then right bending right knee.

### Repetition(s)

5.

---

---

---

---

---

---

---

### MOVEMENT 2.3.3

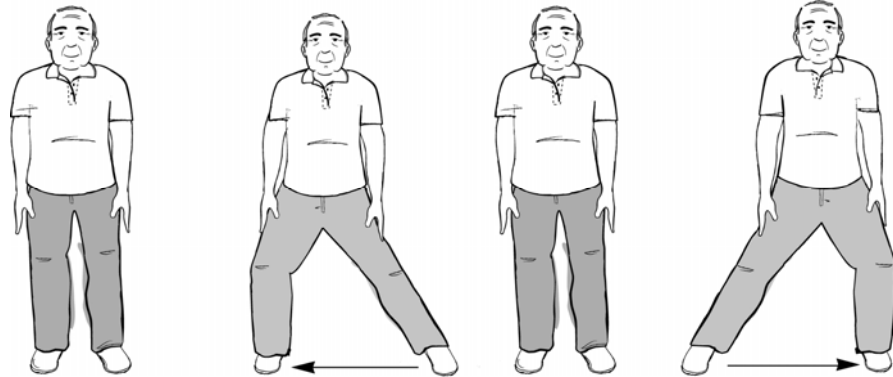

#### Objectives

To improve static balance when transferring weight to the right and then to the left. Helps achieve better control of limits of stability range.

#### Starting position

- standing, back straight;
- arms straight down by your sides;
- feet hip-width apart.

#### Exercise

Step right, transferring your body weight to the right leg by bending your right knee. Return to starting position and step left, transferring your body weight to the left leg by bending left knee.

#### Repetition(s)

5 per movement.

- 1st movement: step right;
- 2nd movement: step left.

---

---

---

---



## MOVEMENT 2.4.1

### Objective

To improve static balance standing on one leg.

### Starting position

- standing, back straight;
- arms straight down by your sides;
- feet hip-width apart, right leg raised in front of you.



### Exercise

Hold the position.

### Hold for

5 to 10 seconds for each leg.

---

---

---

---

---

---

---

---

## MOVEMENT 2.4.2

### Objective

To improve static balance standing on one leg.

### Starting position

- standing, back straight;
- arms straight down by your sides;
- right leg raised to the side.

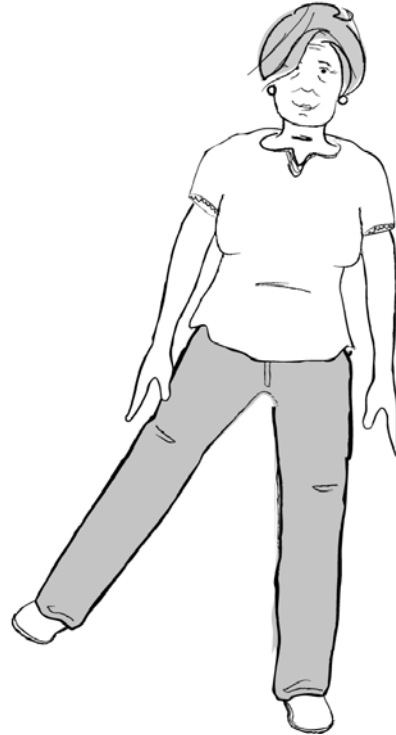

### Exercise

Hold the position.

### Hold for

5 to 10 seconds for each leg.

---

---

---

---

---

---

---

---

---

---

### MOVEMENT 2.4.3

#### Objective

To improve static balance standing on one leg.

#### Starting position

- standing, back straight;
- arms straight down by your sides;
- feet hip-width apart, right leg raised behind you.

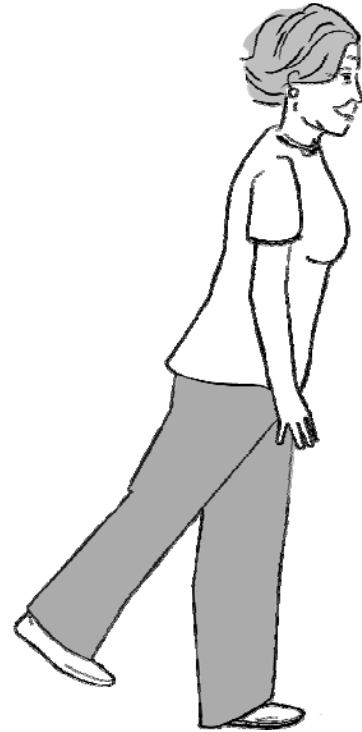

#### Exercise

Hold the position.

#### Hold for

5 to 10 seconds for each leg.

---

---

---

---

---

---

---

---



## ENGLISH VERSION BASIC MOVEMENTS-MOTOR CAPACITIES

### DYNAMIC BALANCE: BASIC MOVEMENTS

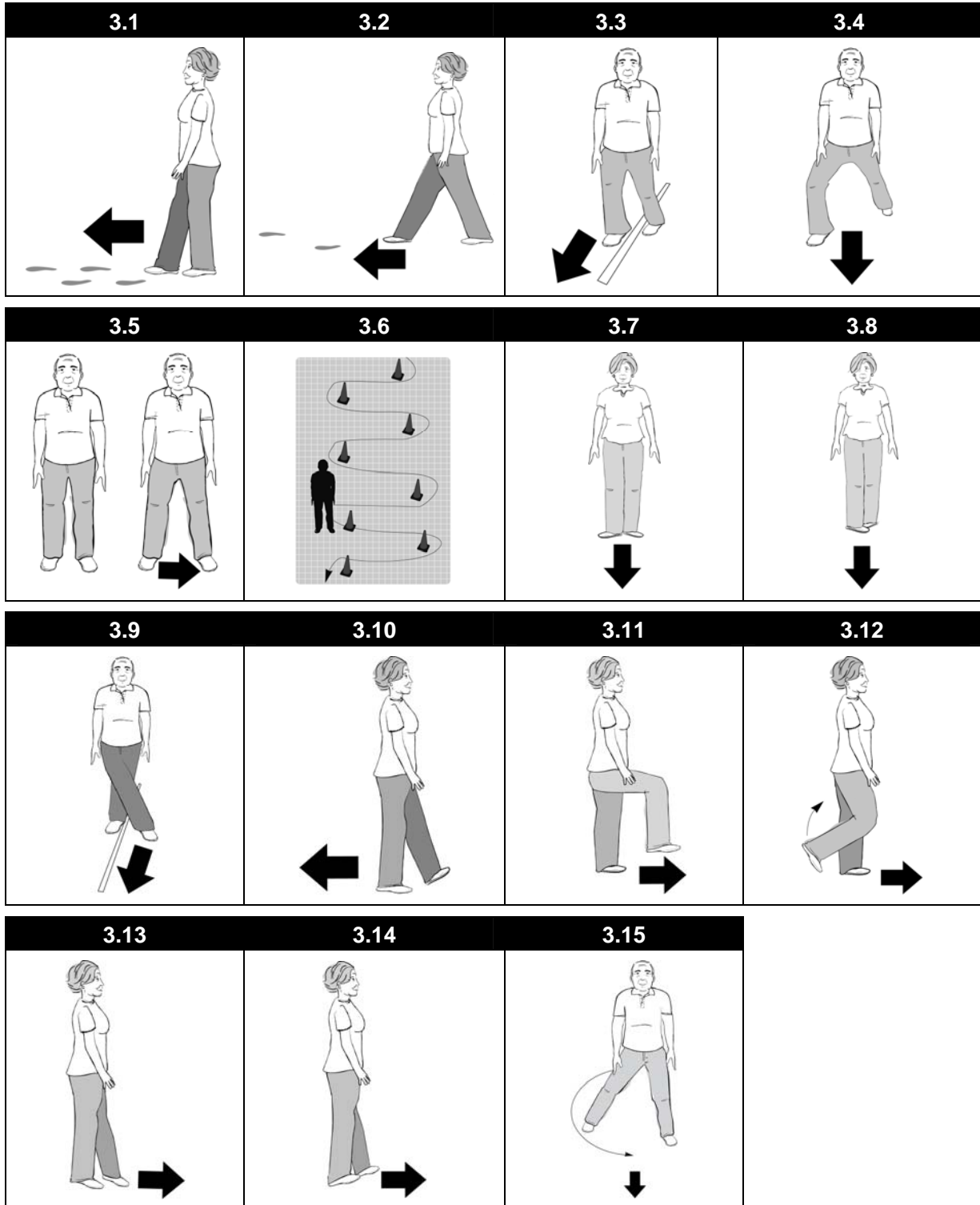



### MOVEMENT 3.1

#### Objective

To improve dynamic balance by changing your walking pattern; taking small steps.

#### Starting position

- standing, back straight;
- arms straight down by your sides;
- feet flat on the floor, hip-width apart.

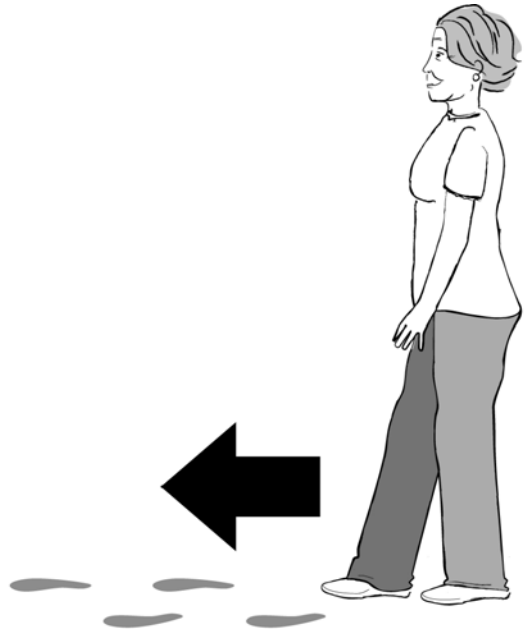

#### Exercise

Keeping your feet hip-width apart, walk taking small steps (place your right heel close to the toes of your left foot, then your left heel close to the toes of your right foot).

#### Distance

3 to 5 metres.

---

---

---

---

---

---

---

---

---

---

## MOVEMENT 3.2

### Objective

To improve dynamic balance by changing your walking pattern; taking big steps.

### Starting position

- standing, back straight;
- arms straight down by your sides;
- feet flat on the floor, hip-width apart.

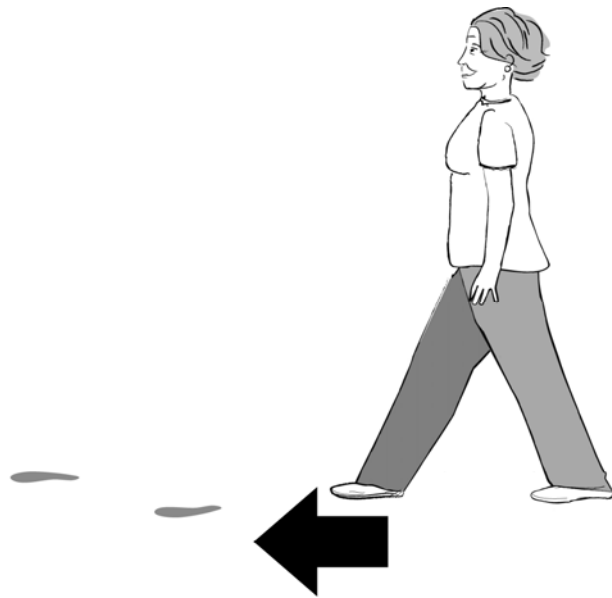

### Exercise

Walk in a straight line taking big steps (longer than usual).

### Distance

3 to 5 metres.

---

---

---

---

---

---

---

---



### MOVEMENT 3.3

#### Objective

To improve dynamic balance by changing your walking pattern; taking narrow steps.

#### Starting position

- standing, back straight;
- arms straight down by your sides;
- strip of adhesive tape on the floor;
- feet on either side of adhesive tape.

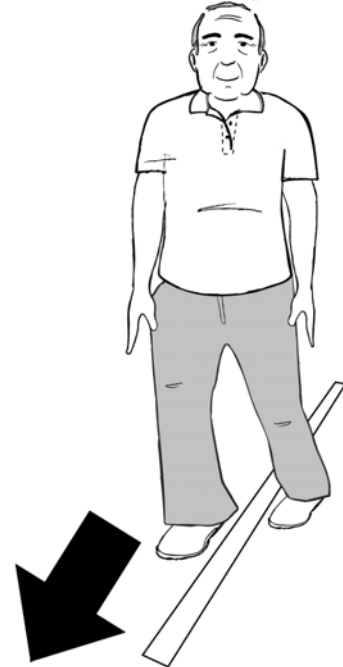

#### Equipment

Strip of adhesive tape 3 to 5 metres long.

#### Exercise

Walk taking narrower steps than usual (feet on either side of the adhesive strip).

#### Distance

3 to 5 metres.

---

---

---

---

---

---

## MOVEMENT 3.4

### Objective

To improve dynamic balance by changing your walking pattern; taking wide steps.

### Starting position

- standing, back straight;
- arms straight down by your sides;
- feet flat on the floor, hip-width apart.



### Exercise

Walk in a straight line taking wider steps than usual.

### Distance

3 to 5 metres.

---

---

---

---

---

---

---

---

---

---

### MOVEMENT 3.5

#### Objective

To improve dynamic balance by changing your walking pattern; taking side steps.

#### Starting position

- standing, back straight;
- arms straight down by your sides;
- feet flat on the floor, hip-width apart.

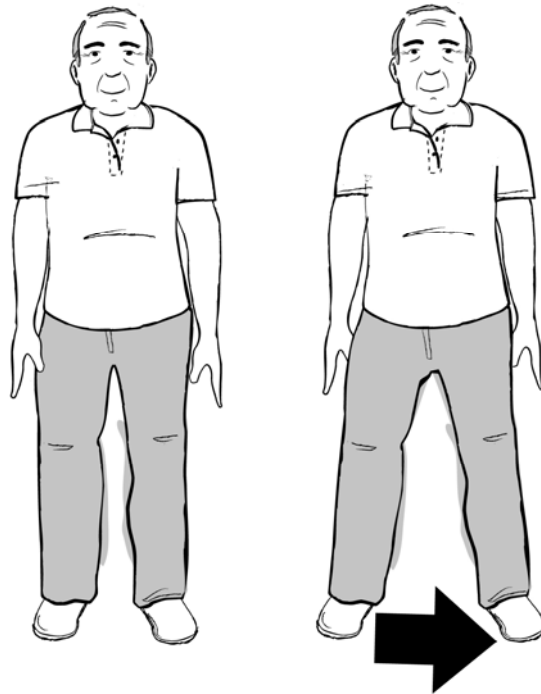

#### Exercise

Walk sideways taking steps to the left side, then to the right side.

#### Distance

3 to 5 metres.

---

---

---

---

---

---

---

---

## MOVEMENT 3.6

### Objective

To improve dynamic balance by changing your walking pattern; changing direction as you walk.

### Starting position

- standing, back straight;
- arms straight down by your sides;
- feet flat on the floor, hip-width apart;
- cones placed on the floor in alternating pattern.

### Equipment

About 10 cones.

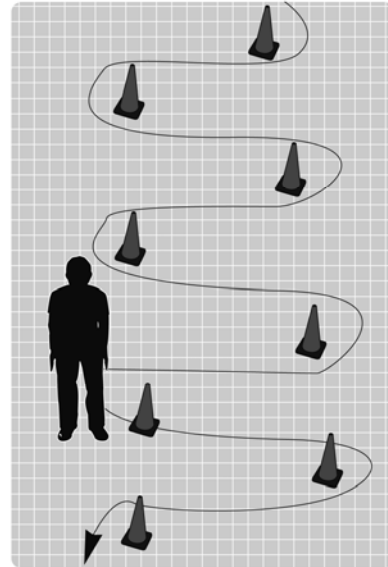

### Exercise

Walk circling around the outside of the cones.

### Distance

3 to 5 metres.

---

---

---

---

---

---

## MOVEMENT 3.7

### Objective

To improve dynamic balance by changing your walking pattern; walking with feet turned out.

### Starting position

- standing, back straight;
- arms straight down by your sides;
- feet flat on the floor and open at about a 45° angle, heels together.

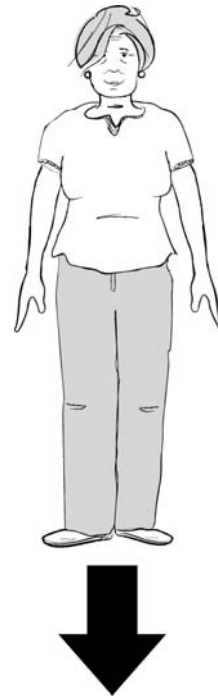

### Exercise

Walk keeping feet turned out.

### Distance

3 to 5 metres.

---

---

---

---

---

---

---

---

## MOVEMENT 3.8

### Objective

To improve dynamic balance by changing your walking pattern; walking with toes turned in.

### Starting position

- standing, back straight;
- arms straight down by your sides;
- feet flat on the floor, toes turned in, heels turned out as far as you can within your flexibility range.

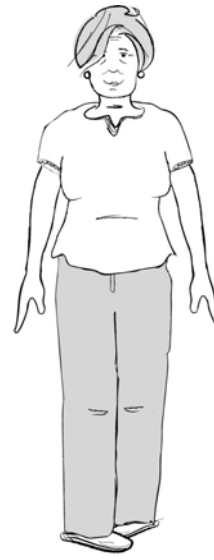

### Exercise

Walk in a straight line keeping your toes turned in.

### Distance

3 to 5 metres.

---

---

---

---

---

---

---

---

## MOVEMENT 3.9

### Objective

To improve dynamic balance by changing your walking pattern; crossing your legs as you walk.

### Starting position

- standing, back straight;
- arms straight down by your sides;
- strip of adhesive tape on the floor;
- legs crossed, feet flat on the floor on either side of the adhesive tape.

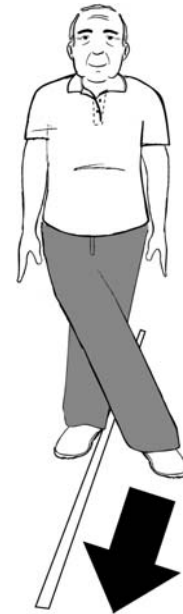

### Equipment

Strip of adhesive tape about 3 metres long.

### Exercise

Walk crossing your legs so that you place your feet on either side of the tape.

### Distance

3 to 5 metres.

---

---

---

---

---

---

## MOVEMENT 3.10

### Objective

To improve dynamic balance by changing your walking pattern; walking backwards.

### Starting position

- standing, back straight;
- arms straight down by your sides;
- feet flat on the floor, hip-width apart.

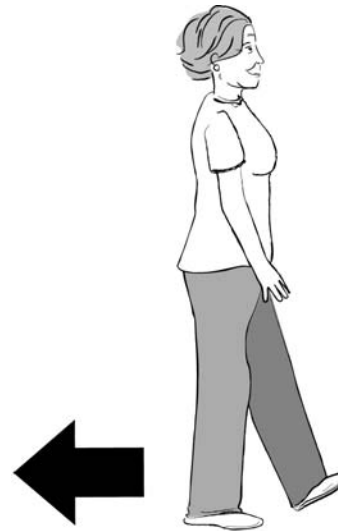

### Exercise

Walk backwards.

### Distance

3 to 5 metres.

---

---

---

---

---

---

---

---



### MOVEMENT 3.11

#### Objective

To improve dynamic balance by changing your walking pattern; lifting your thighs in front as you walk.

#### Starting position

- standing, back straight;
- arms straight down by your sides;
- feet flat on the floor, hip-width apart.

#### Exercise

Walk in a straight line lifting your thigh with every step.

#### Distance

3 to 5 metres.

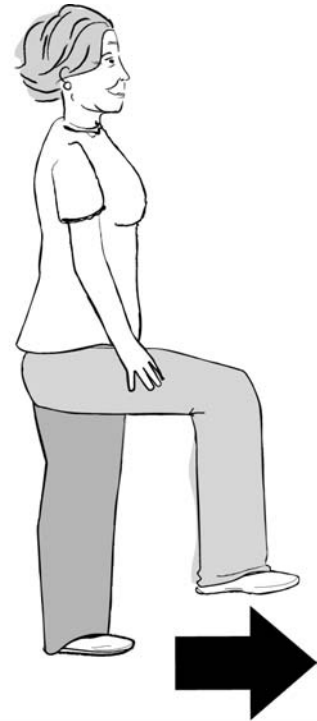

---

---

---

---

---

---

---

---

## MOVEMENT 3.12

### Objective

To improve dynamic balance by changing your walking pattern; flexing leg backward as you walk.

### Starting position

- standing, back straight;
- arms straight down by your sides;
- feet flat on the floor, hip-width apart.

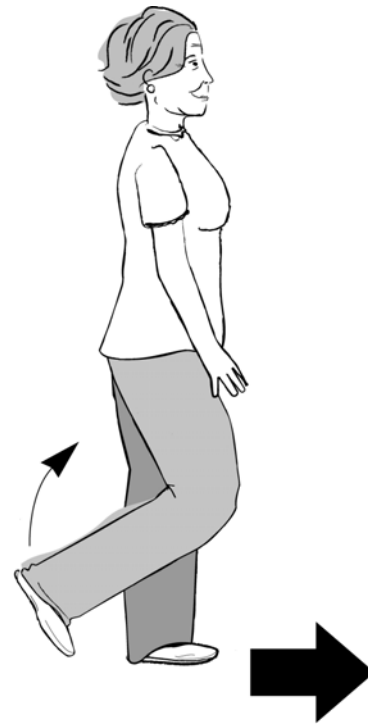

### Exercise

Walk in a straight line flexing your leg backward, heel raised toward your buttocks.

### Distance

3 to 5 metres.

---

---

---

---

---

---

---

---

### MOVEMENT 3.13

#### Objective

To improve dynamic balance by changing your walking pattern; walking on the balls of your feet, without letting your heels touch the floor.

#### Starting position

- standing, back straight;
- arms straight down by your sides;
- feet flat on the floor, hip-width apart.

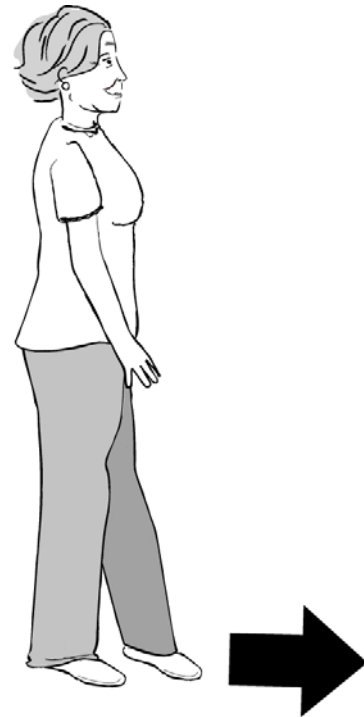

#### Exercise

Walk in a straight line on the balls of your feet, keeping your heels off the floor.

#### Distance

3 to 5 metres.

---

---

---

---

---

---

---

### MOVEMENT 3.14

#### Objective

To improve dynamic balance by changing your walking pattern; walking on your heels.

#### Starting position

- standing, back straight;
- arms straight down by your sides;
- feet flat on the floor, hip-width apart.

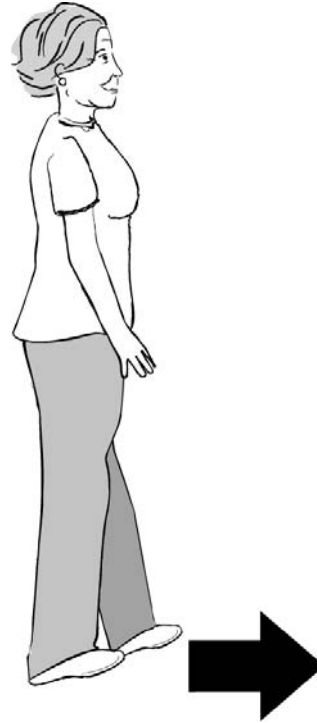

#### Exercise

Walk in a straight line on your heels, keeping the balls of your feet off the floor.

#### Distance

3 to 5 metres.

---

---

---

---

---

---

---

---

---

---

### MOVEMENT 3.15

#### Objective

To improve dynamic balance by changing your walking pattern; walking with leg abductions.

#### Starting position

- standing, back straight;
- arms straight down by your sides;
- feet flat on the floor, hip-width apart.

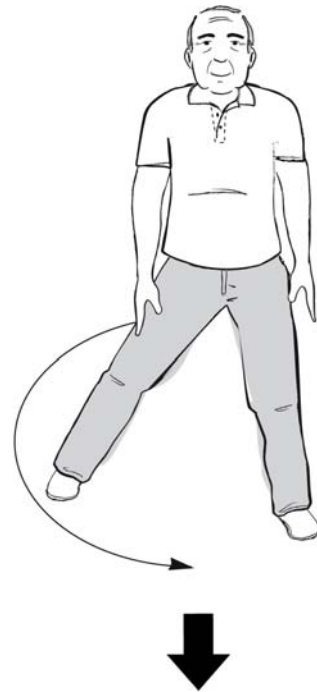

#### Exercise

Walk in a straight line making an abduction at each step with the leg raised off the floor (leg makes a half-circle forward).

#### Distance

3 to 5 metres.

---

---

---

---

---

---

---

---



## ENGLISH VERSION BASIC MOVEMENTS-MOTOR CAPACITIES

### MUSCLE STRENGTHENING: BASIC MOVEMENTS

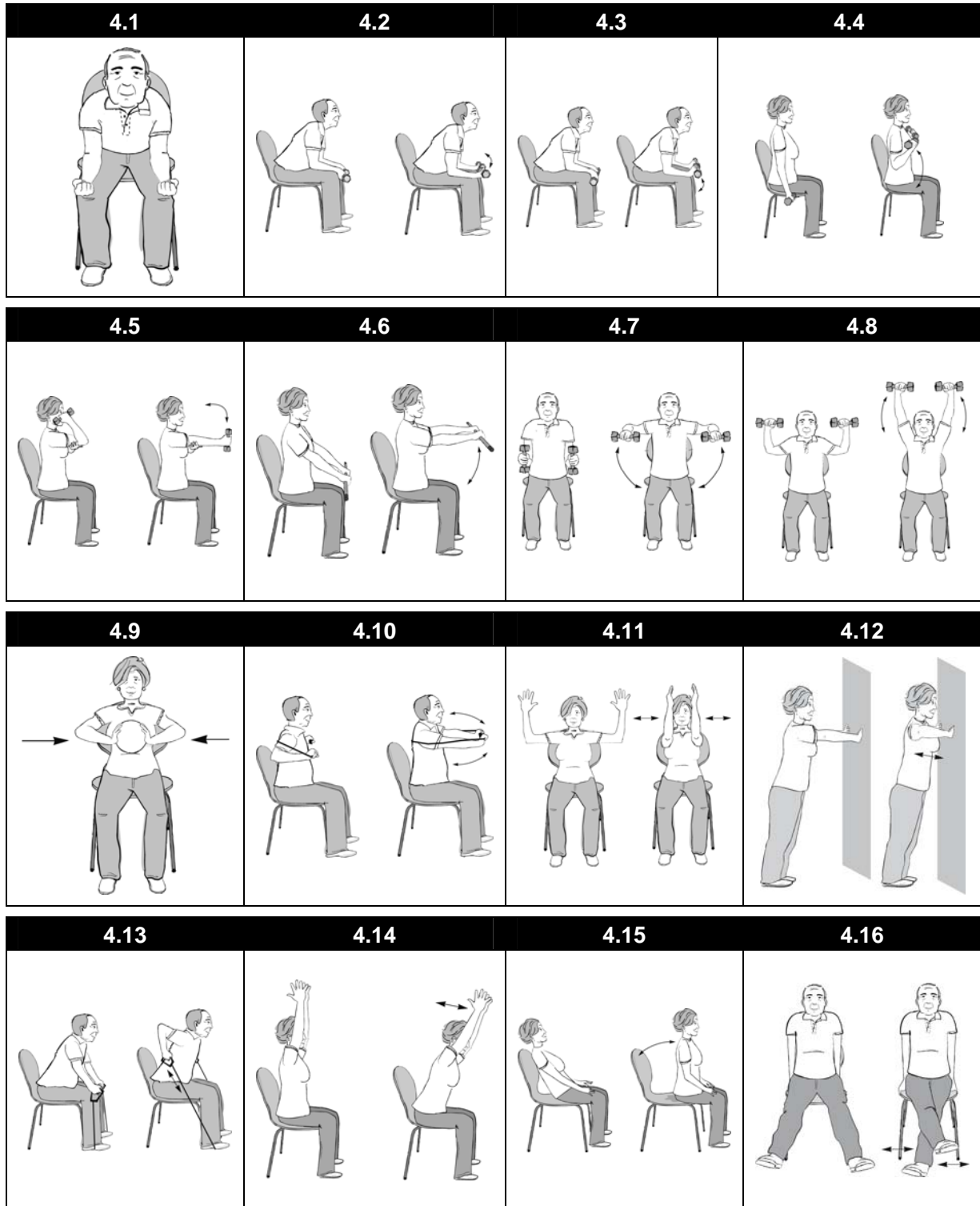

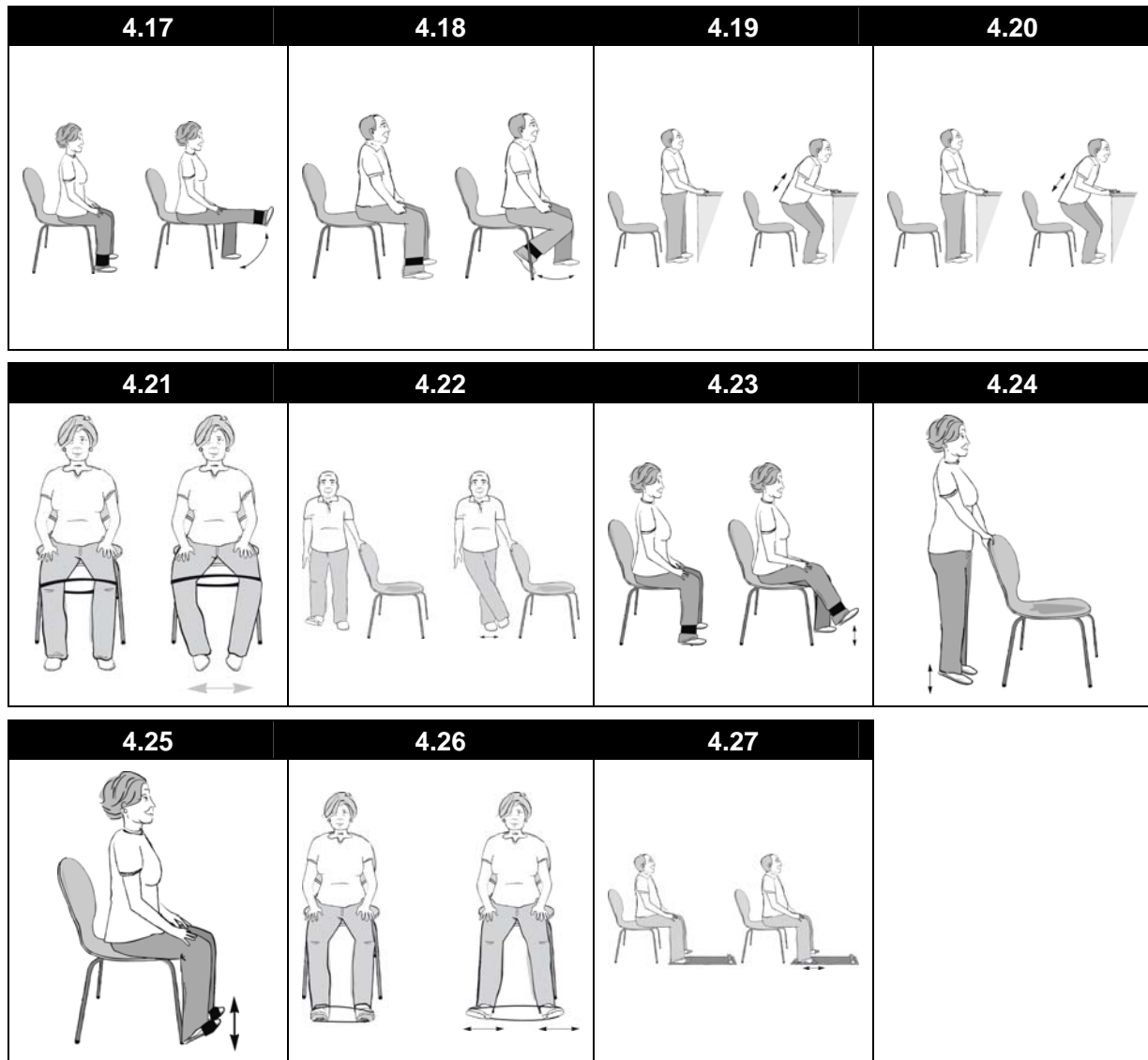



## MOVEMENT 4.1

### Strengthening exercise for:

Hands, fingers, forearms.

### Starting position

- seated, back straight;
- forearms resting on thighs;
- feet flat on the floor, hip-width apart.

### Equipment (optional)

Balls, elastic bands.

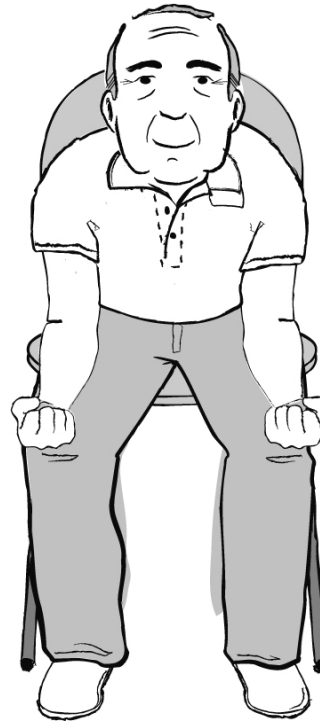

### Exercise

Close fists, squeeze for 2 seconds and release.

### Repetition(s)

1 set of 12 to 15.

---

---

---

---

---

---

---

---

## MOVEMENT 4.2

### Strengthening exercise for:

Forearms

#### Starting position

- seated, back straight;
- forearms resting on thighs (wrists on knees), palms up;
- hand weight in each hand (optional);
- feet flat on the floor, hip-width apart.

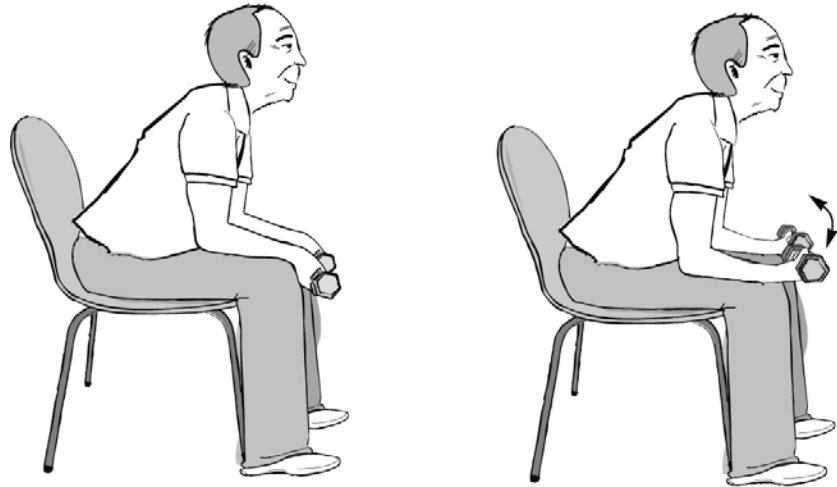

#### Equipment (optional)

Hand weights, wrist weights, elastic tubing, elastic band, bottles of water or cans.

#### Exercise

Flex and extend wrists.

#### Repetition(s)

1 set of 12 to 15.

---

---

---

---

## MOVEMENT 4.3

### Strengthening exercise for:

Forearms

### Starting position

- seated, back straight;
- forearms resting on thighs (wrists on knees), palms down;
- hand weight in each hand (optional);
- feet flat on floor, hip-width apart.

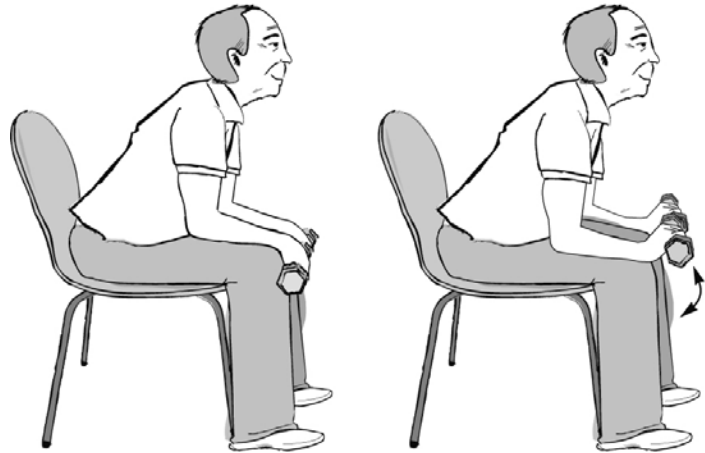

### Equipment (optional)

Hand weights, wrist weights, elastic tubing, elastic band, bottles of water or cans.

### Exercise

Flex and extend wrists.

### Repetition(s)

1 set of 12 to 15.

---

---

---

## MOVEMENT 4.4

### Strengthening exercise for:

Arms

#### Starting position

- seated, back straight, lower back against chair back;
- arms straight down by your sides;
- hand weight in each hand (optional);
- feet flat on the floor, hip-width apart.

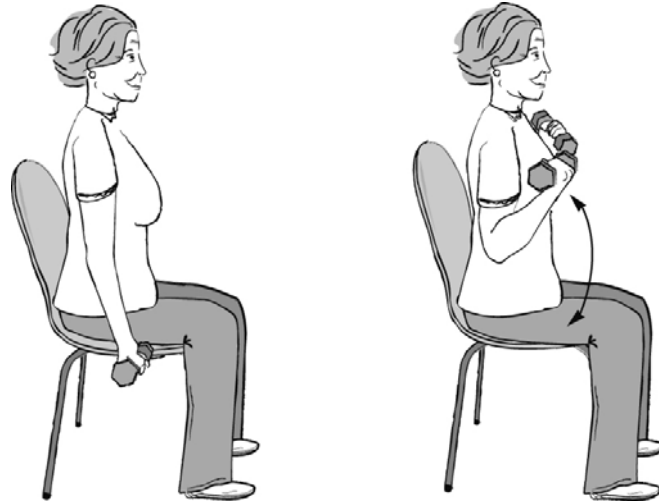

#### Equipment (optional)

Hand weights, wrist weights, elastic tubing, elastic band, bottles of water or cans.

#### Exercise

Keeping upperarms close to your sides, flex and then extend forearms.

#### Repetition(s)

1 set of 12 to 15.

---

---

---

---

## MOVEMENT 4.5

### Strengthening exercise for:

Arms

#### Starting position

- seated, back straight, lower back against chair back;
- right arm raised to shoulder level and bent so that your hand is beside your ear. Support this arm with your left hand;
- weight in right hand (optional);
- feet flat on the floor, hip-width apart.

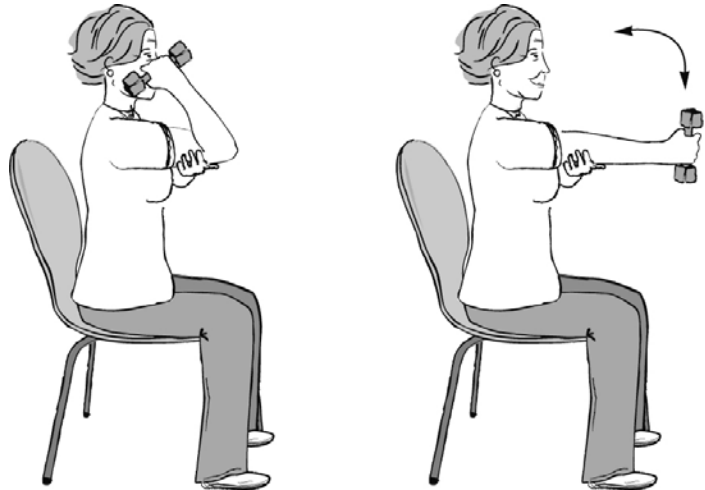

#### Equipment (optional)

Hand weights, wrist weights, elastic tubing, elastic band, bottles of water or cans.

#### Exercise

Keeping upper arm still, straighten and then bend forearm.

#### Repetition(s)

1 set of 12 to 15 with each arm.

---

---

---

## MOVEMENT 4.6

### Strengthening exercise for:

Shoulders

#### Starting position

- seated, back straight, lower back against chair back;
- arms straight forward;
- holding wooden stick (optional);
- feet flat on the floor, hip-width apart.

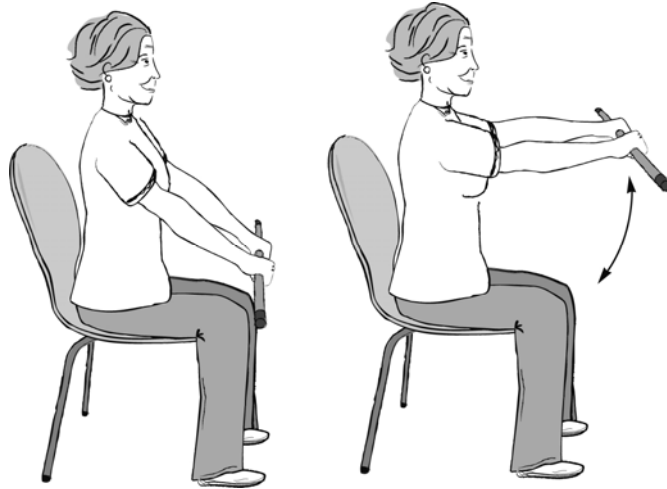

#### Equipment (optional)

Wooden stick, free weight bar, hand weights, wrist weights, elastic tubing, elastic band, bottles of water or cans.

#### Exercise

Raise arms in front of you to shoulder level and then return to starting position.

#### Repetition(s)

1 set of 12 to 15.

---

---

---

---

## MOVEMENT 4.7

### Strengthening exercise for:

Shoulders

#### Starting position

- seated, back straight, lower back against chair back;
- arms close to you sides and elbows at 90° angle;
- weights in hands (optional);
- palms facing each other;
- feet flat on the floor, hip-width apart.

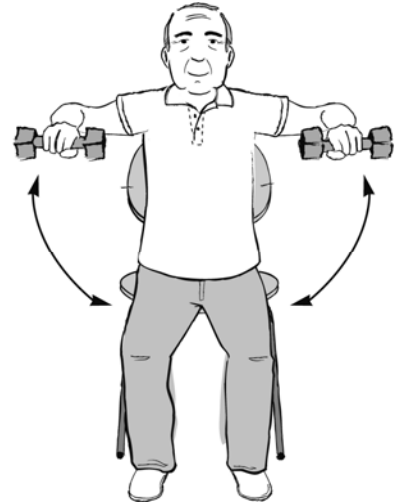

#### Equipment (optional)

Hand weights, wrist weights, elastic tubing, elastic band, bottles of water or cans.

#### Exercise

Raise arms to shoulder level and return to starting position. Maintain 90° angle throughout the movement.

#### Repetition(s)

1 set of 12 to 15.

---

---

---

## MOVEMENT 4.8

### Strengthening exercise for:

Shoulders.

### Starting position

- seated, back straight, lower back against chair back;
- arms raised to sides at shoulder level, elbows at 90° angle, hands directed up toward the ceiling;
- weights in hands (optional);  
feet flat on the floor, hip-width apart.

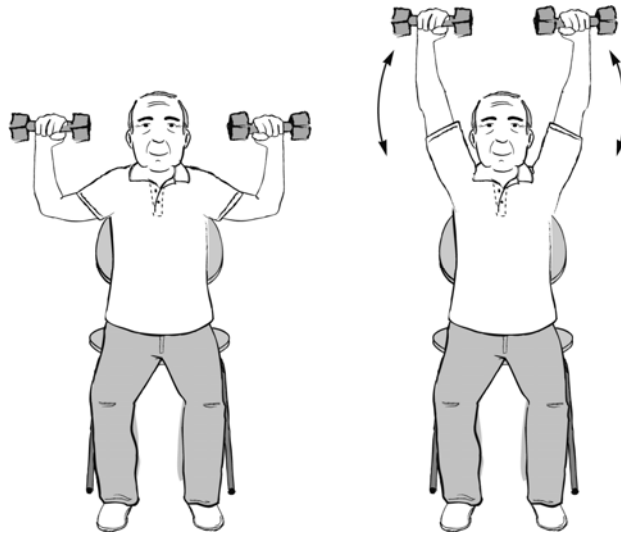

---

### Safety Tip

This movement may be contra-indicated for persons with a spinal deformation (kyphosis) due to osteoporosis.

---

### Exercise

Straighten arms upward and then return to starting position.

### Equipment (optional)

Hand weights, wrist weights, elastic tubing, elastic band, wooden stick, free weight bar, bottles of water or cans.

### Repetition(s)

1 set of 12 to 15.

---

---

---

---



## MOVEMENT 4.9

### Strengthening exercise for:

Hands, fingers, chest.

### Starting position

- seated, back straight, lower back against chair back;
- arms raised and bent at chest level;
- rubber ball between hands (optional);
- feet flat on the floor, hip-width apart.

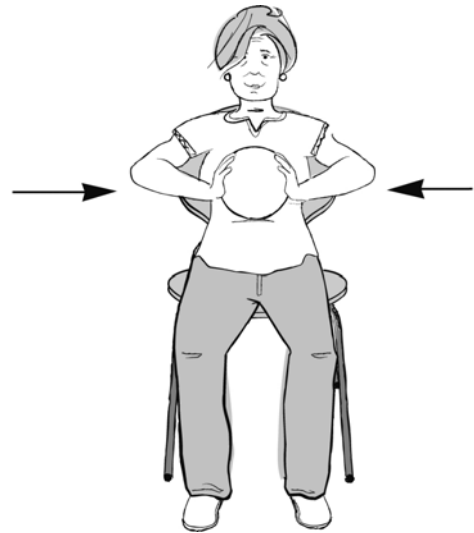

### Equipment (optional)

Ball.

---

### Safety Tip

Do not hold your breath.

---

### Exercise

Squeeze ball between your hands for 2 seconds and release. If no ball, squeeze palms together.

### Repetition(s)

1 set of 12 to 15.

---

---

---

---

---

---

## MOVEMENT 4.10

**Strengthening exercise for:**  
Shoulders, chest.

### Starting position

- seated, back straight, lower back against chair back;
- arms raised at your sides to shoulder level, forming a 90° angle, hands at shoulder level;
- elastic tubing passed behind your back and held in your hands (optional);
- feet flat on the floor, hip-width apart.

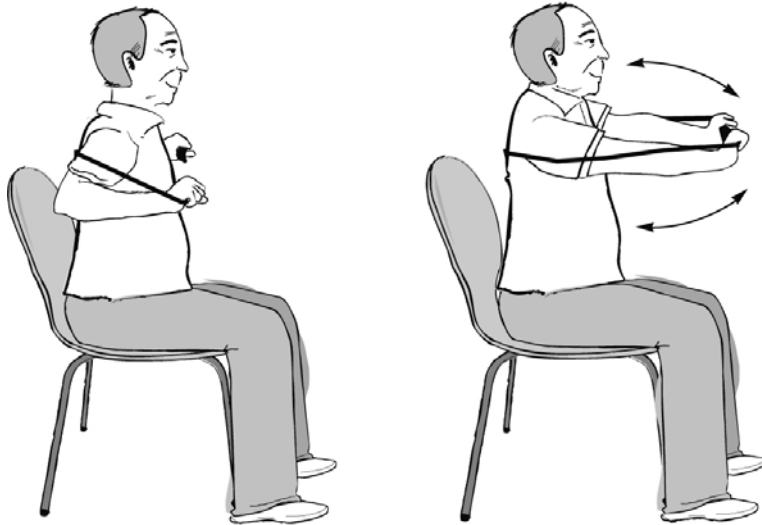

### Equipment (optional)

Elastic tubing, hand weights, wrist weights, elastic band, wooden stick, free weight bar, bottles of water or cans.

### Exercise

Stretch arms out in front of you and come back to starting position. If the position of the elastic is uncomfortable, it can be placed under the arms.

### Repetition(s)

1 set of 12 to 15.

---

---

---

## MOVEMENT 4.11

### Strengthening exercise for:

Shoulders, chest.

### Starting position

- seated, back straight, lower back against chair back;
- arms raised to sides at shoulder level, elbows at 90° angle, hands at head level pointing upward;
- feet flat on the floor, hip-width apart.

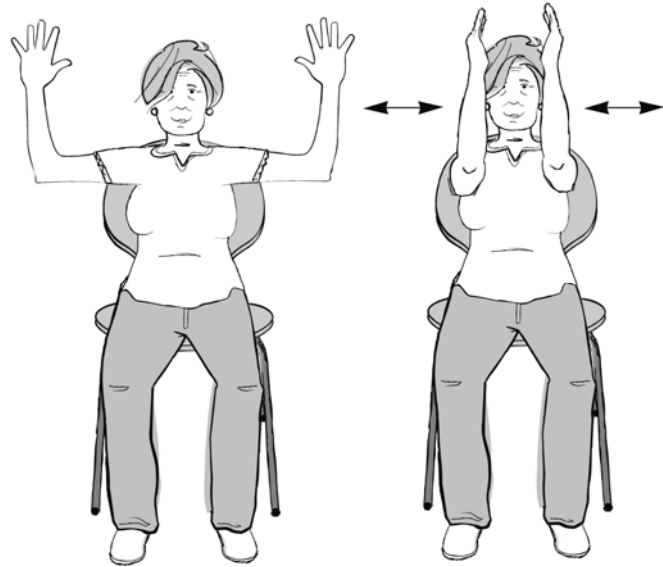

### Equipment (optional)

Hand weights, wrist weights, bottles of water, cans or rubber ball.

### Exercise

Close and open arms.

### Repetition(s)

1 set of 12 to 15.

---

---

---

---

---

---

## MOVEMENT 4.12

### Strengthening exercise for:

Chest, arms.

### Starting position

- standing at arm's length from the wall, back straight (body should form a 45° angle with the wall);
- hands placed on the wall at shoulder level, more than shoulder width apart;
- feet flat on the floor, hip-width apart.

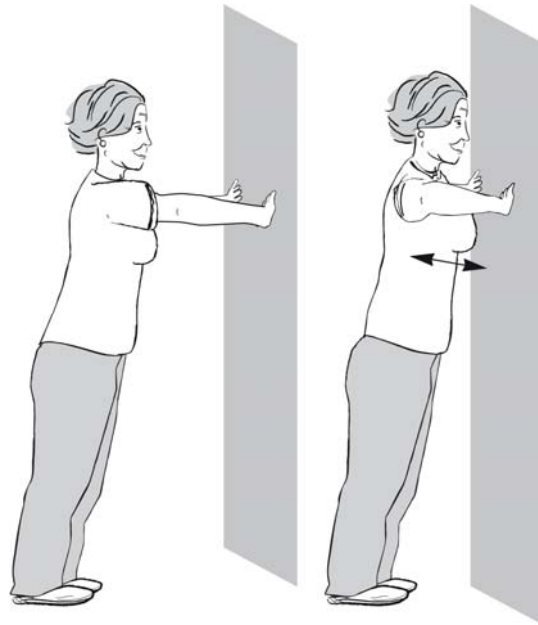

### Exercise

Keeping body straight, bend elbows to form an angle of no more than 90° with your arms; return to starting position.

### Repetition(s)

1 set of 12 to 15.

---

---

---

---

---

---

---

---

## MOVEMENT 4.13

### Strengthening exercise for:

Back

### Starting position

- seated, back straight, upper body bent forward at about 45° angle;
- arms straight down outside of knees, palms facing each other;
- elastic tubing (optional) in hands;
- feet flat on the floor, hip-width apart and placed on the elastic tubing.

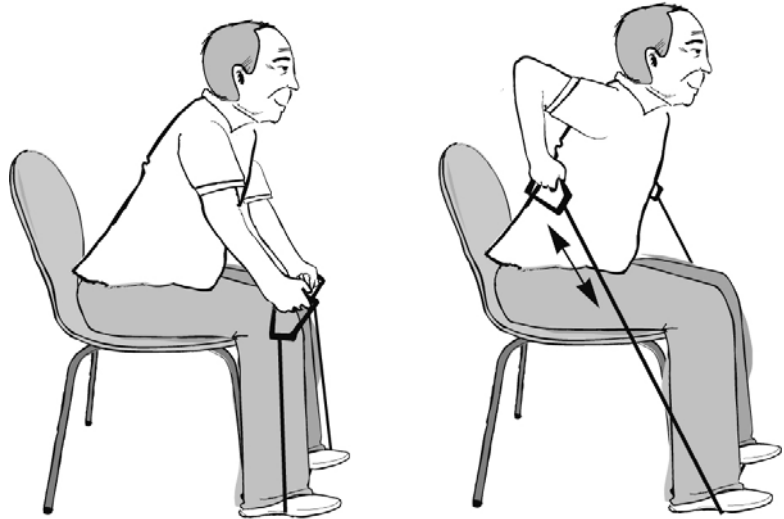

### Equipment (optional)

Elastic tubing, hand weights, wrist weights, elastic band, wooden stick, free weight bar, bottles of water or cans.

### Exercise

Pull arms back until hands are level with chest and then return to starting position.

### Repetition(s)

1 set of 12 to 15.

---

---

---

## MOVEMENT 4.14

### Strengthening exercise for:

Back

### Starting position

- seated, back straight, lower back against chair back;
- arms fully extended upward;
- feet flat on the floor, hip-width apart.

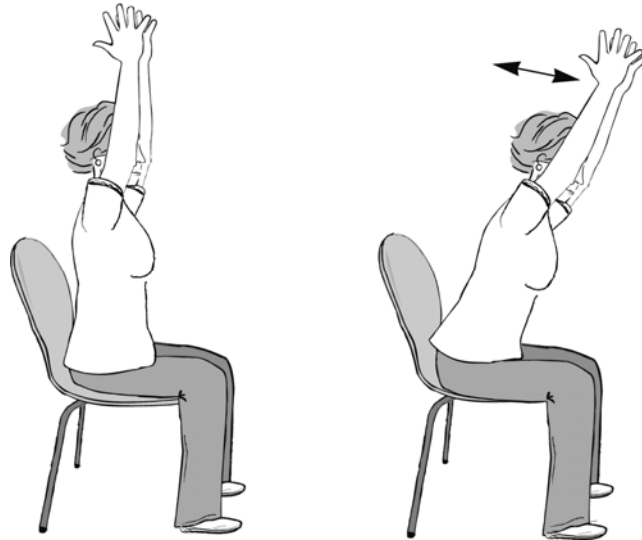

### Equipment (optional)

Hand weights, wrist weights, bottles of water or cans.

### Exercise

Bend upper body forward keeping arms extended at either side of your head; return to starting position.

### Repetition(s)

1 set of 12 to 15.

---

---

---

---

---

---

## MOVEMENT 4.15

### Strengthening exercise for:

Abdomen.

### Starting position

- seated in the centre of the chair, back straight, upper back leaning against back of chair;
- hands resting on thighs;
- feet flat on the floor, hip-width apart.

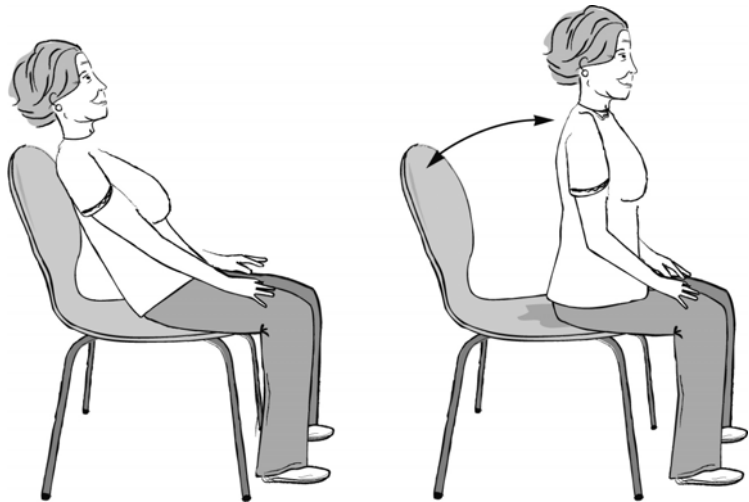

### Equipment (optional)

Hand weights.

### Exercise

Keeping feet flat on the floor, bend upper body forward and then return to starting position.

### Repetition(s)

1 set of 12 to 15.

---

---

---

---

---

---

## MOVEMENT 4.16

### Strengthening exercise for:

Abdomen, hips, thighs.

### Starting position

- seated in the centre of the chair, back straight, upper back leaning against back of chair;
- arms straight down by your sides, hands holding the seat;
- legs wide, stretched out in front and raised from the floor.

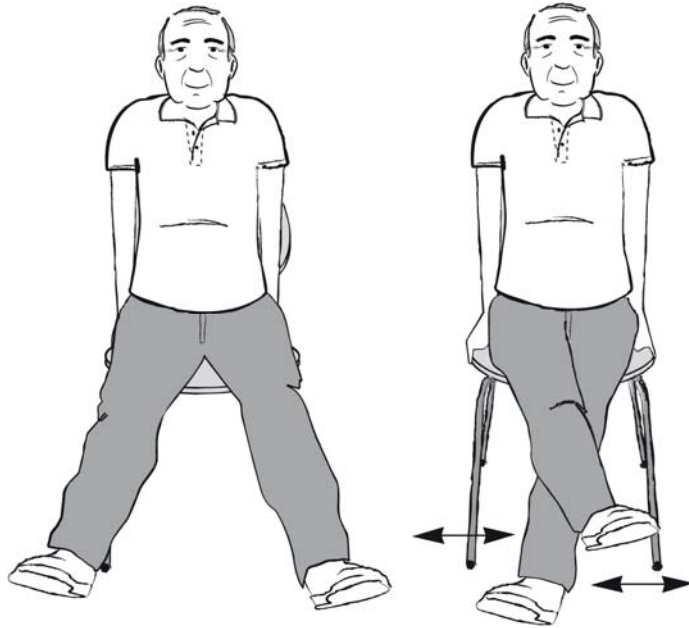

### Equipment (optional)

Ankle weights.

### Exercise

Cross and uncross legs.

### Repetition(s)

1 set of 12 to 15.

---

---

---

---

---

---



## MOVEMENT 4.17

### Strengthening exercise for:

Thighs

### Starting position

- seated in the centre of the chair, back straight;
- hands resting on thighs;
- ankle weights (optional);
- feet flat on the floor, hip-width apart.

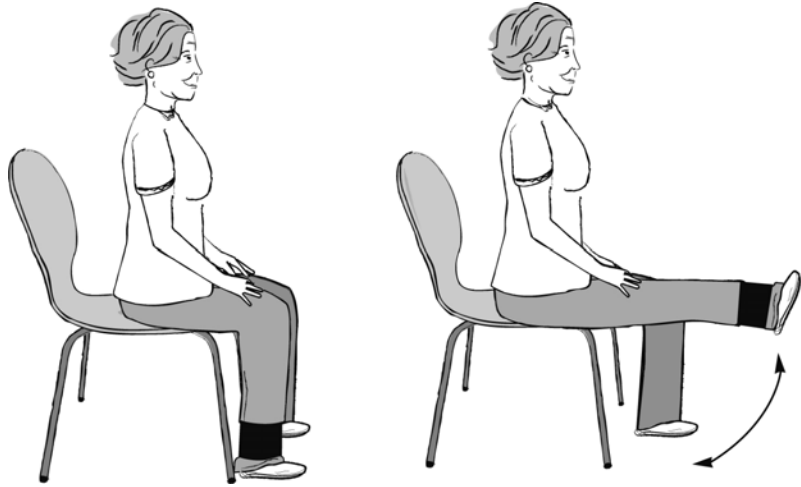

### Equipment (optional)

Ankle weights, knotted elastic tubing or elastic band.

### Exercise

Extend right leg and return to starting position.

### Repetition(s)

1 set of 12 to 15 for each leg.

---

---

---

---

---

---

## MOVEMENT 4.18

### Strengthening exercise for:

Thighs

### Starting position

- seated well forward on the chair, back straight;
- hands resting on thighs;
- ankle weights (optional);
- feet flat on the floor, hip-width apart.

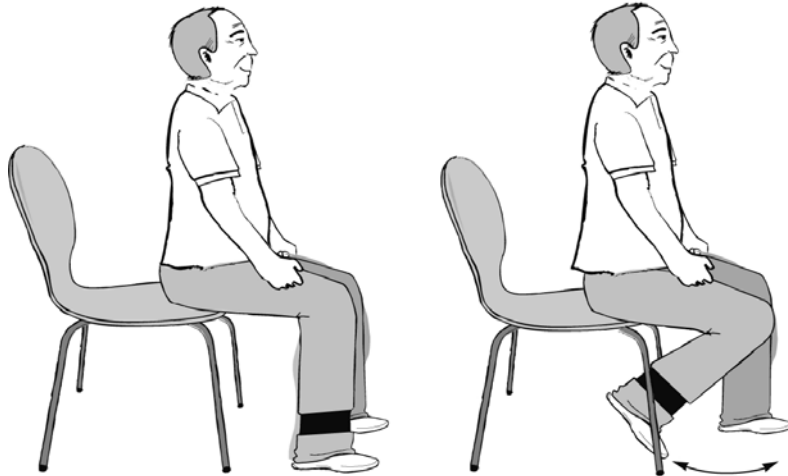

### Equipment (optional)

Ankle weights, knotted elastic tubing or elastic band.

### Exercise

Bend right knee to bring right foot under the chair and then return to starting position.

### Repetition(s)

1 set of 12 to 15 for each leg.

---

---

---

---

## MOVEMENT 4.19

### Strengthening exercise for:

Buttocks, thighs.

### Starting position

- standing in front of a chair, back straight;
- hands resting on a stable object (ex: table, back of chair, ...);
- feet flat on the floor, hip-width apart.

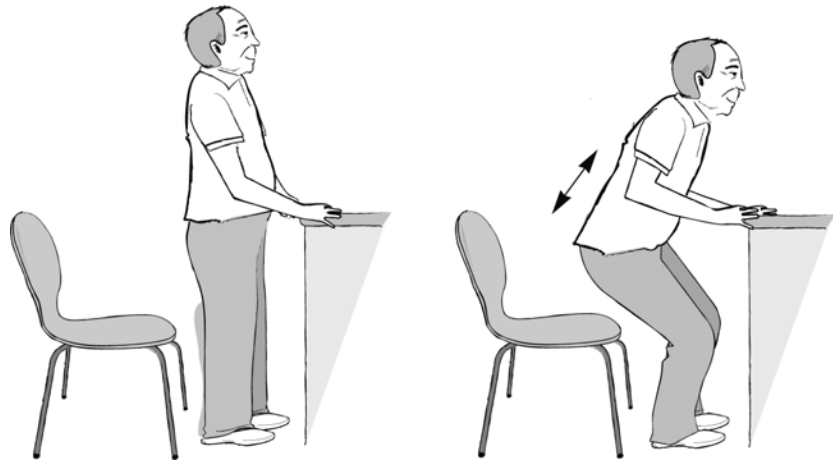

---

### Safety Tip

Be very careful when bending your knees; they should not be turned inward and should not extend beyond your toes.

---

### Exercise

Bend knees no more than 90°, lower buttocks toward the chair, but do not sit down; return to starting position. Body weight should be on the legs, not the arms.

### Repetition(s)

1 set of 12 to 15.

---

---

---

---

---

---

---

---

## MOVEMENT 4.20

### Strengthening exercise for:

Buttocks

### Starting position

- standing, back straight;
- hands resting on a stable object;
- ankle weights (optional);
- feet flat on the floor, hip-width apart.

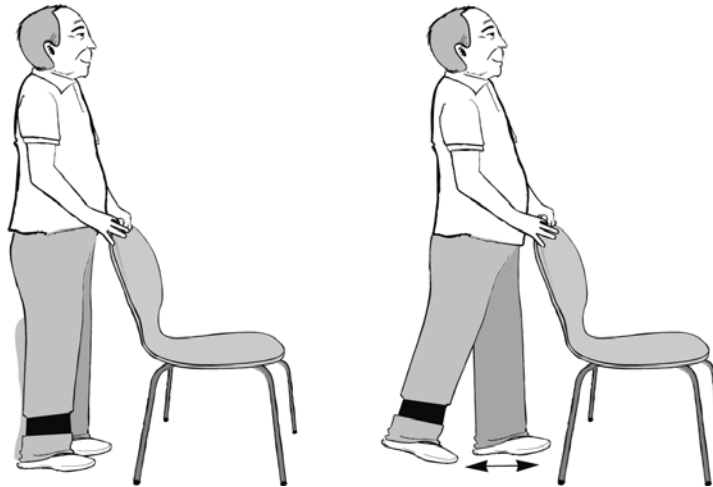

### Equipment (optional)

Ankle weights, knotted elastic tubing or elastic band.

### Exercise

Raise right leg backward and return to starting position.

### Repetition(s)

1 set of 12 to 15 for each leg.

---

---

---

---

---

## MOVEMENT 4.21

### Strengthening exercise for:

Hips and thighs.

### Starting position

- seated in the centre of the chair, back straight;
- hands resting on thighs;
- elastic tubing tied around thighs (optional);
- feet flat on the floor, hip-width apart.

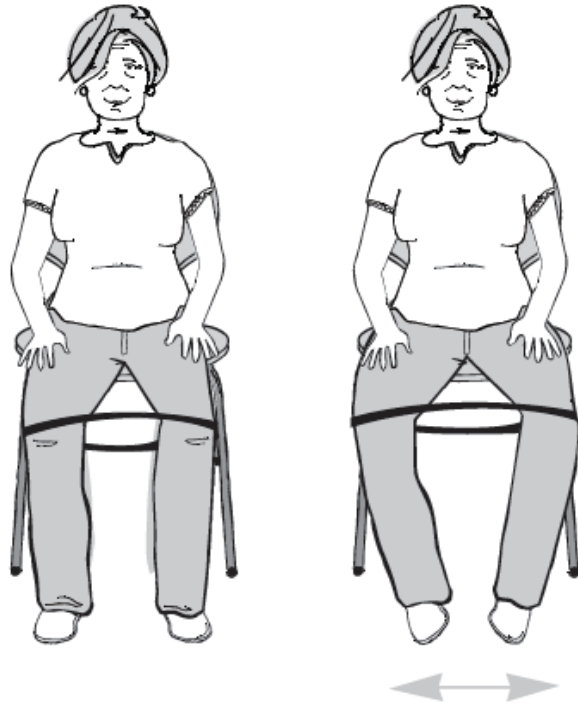

### Equipment (optional)

Knotted elastic tubing or elastic band.

### Exercise

Open thighs, raising soles of feet and return to starting position.

### Repetition(s)

1 set of 12 to 5.

---

---

---

---

---

## MOVEMENT 4.22

### Strengthening exercise for:

Inner thighs

### Starting position

- standing beside a chair, back straight;
- one arm by your side, the other hand resting on chair back;
- one leg raised in front.

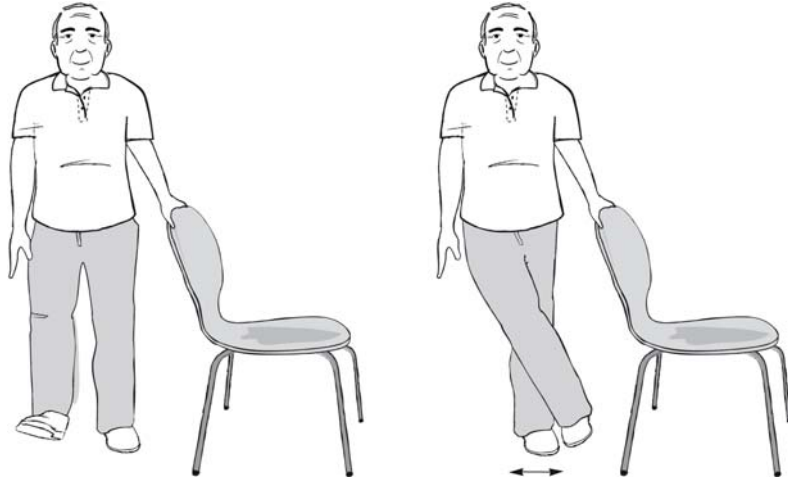

### Equipment (optional)

Ankle weights, knotted elastic tubing or elastic band.

### Exercise

Cross raised leg in front of other and return to starting position.

### Repetition(s)

1 set of 12 to 15 for each leg.

---

---

---

---

---

---

## MOVEMENT 4.23

### Strengthening exercise for:

Hips

### Starting position

- seated, back straight, lower back against chair back;
- hands resting on thighs;
- ankle weights (optional);
- feet flat on the floor, hip-width apart.

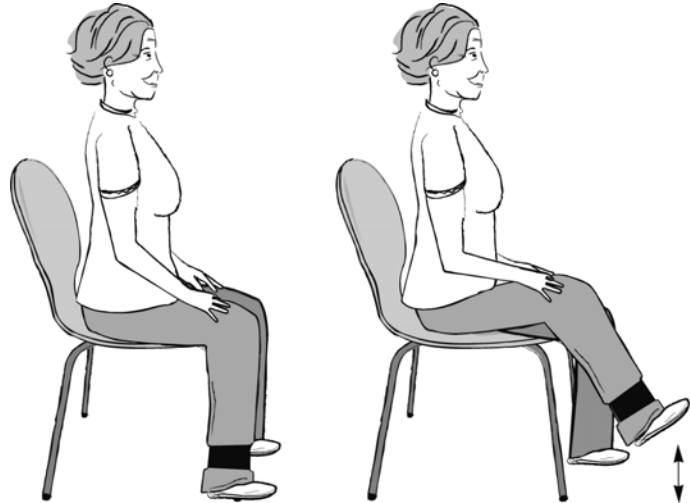

### Equipment (optional)

Ankle weights, knotted elastic tubing or elastic band.

### Exercise

Raise thigh and return to starting position.

### Repetition(s)

1 set of 12 to 15 for each leg.

---

---

---

---

---

---

## MOVEMENT 4.24

### Strengthening exercise for:

Legs

### Starting position

- standing behind a chair, back straight;
- hands resting on back of chair;
- feet flat on the floor, hip-width apart.

### Equipment (optional)

Ankle weights.

### Exercise

Raise heels and return to starting position.

### Repetition(s)

1 set of 12 to 15.



---

---

---

---

---

---

---

---



## MOVEMENT 4.25

### Strengthening exercise for:

Legs

### Starting position

- seated, back straight, lower back against chair back;
- hands resting on thighs;
- ankle weights resting flat on each foot or around ball of foot (optional);
- feet flat on the floor, hip-width apart.

### Equipment (optional)

Ankle weights, knotted elastic tubing or elastic band attached to a stable object.

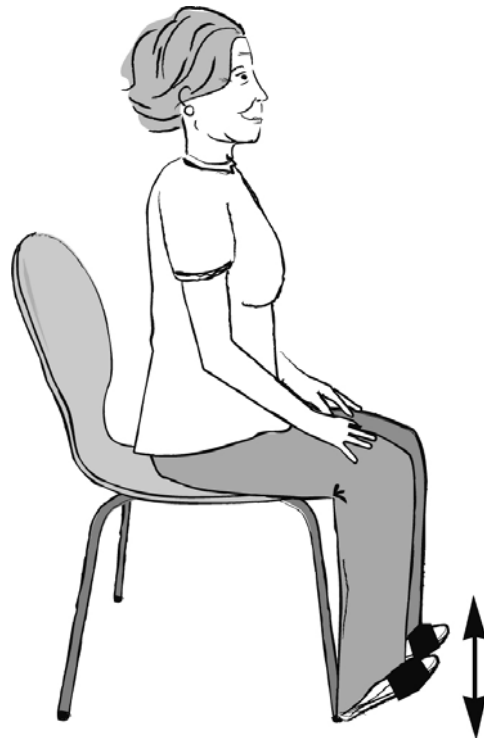

### Exercise

Keeping heels on the floor, raise balls of feet and return to starting position.

### Repetition(s)

1 set of 12 to 15.

---

---

---

---

---

---

## MOVEMENT 4.26

### Strengthening exercise for:

Legs, ankles.

### Starting position

- seated, back straight, lower back against chair back;
- hands resting on thighs;
- elastic tubing tied around the feet (optional);
- heels on the floor, hip-width apart.

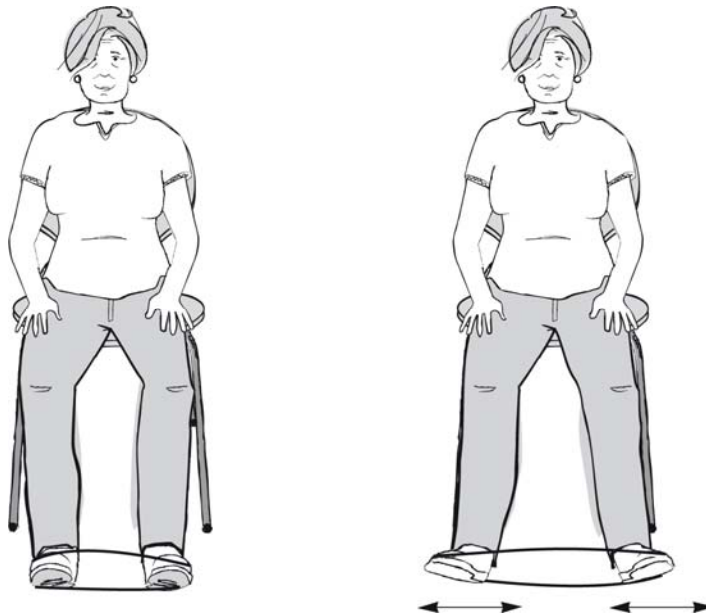

### Equipment (optional)

Knotted elastic tubing or elastic band, ankle weights. It is also possible to do the exercise with one foot by attaching one end of the elastic band or tubing to a stable object and the other end around the foot.

### Exercise

Keeping heels on the floor and legs still, open and close feet. To avoid leg movement, place an object between knees.

### Repetition(s)

1 set of 12 to 15.

---

---

---

## MOVEMENT 4.27

### Strengthening exercise for:

Feet, toes.

### Starting position

- seated, back straight, lower back against chair back;
- hands resting on thighs;
- towel on the floor with a free weight on the end (optional);
- feet flat on the floor, hip-width apart, ball of one foot placed on the towel, no shoes.

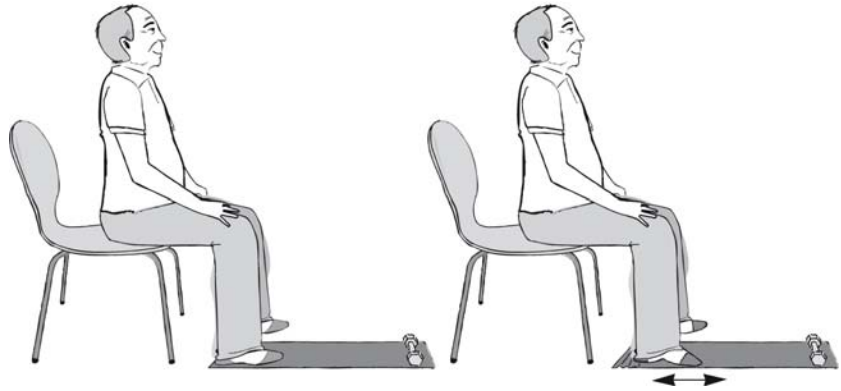

### Equipment (optional)

Towel and free weight.

### Exercise

Without moving right foot, flex toes to pull towel toward right heel.

### Repetition(s)

1 set of 12 to 15 for each foot.

---

---

---

---

---

---



## ENGLISH VERSION BASIC MOVEMENTS-MOTOR CAPACITIES

### FLEXIBILITY: BASIC MOVEMENTS

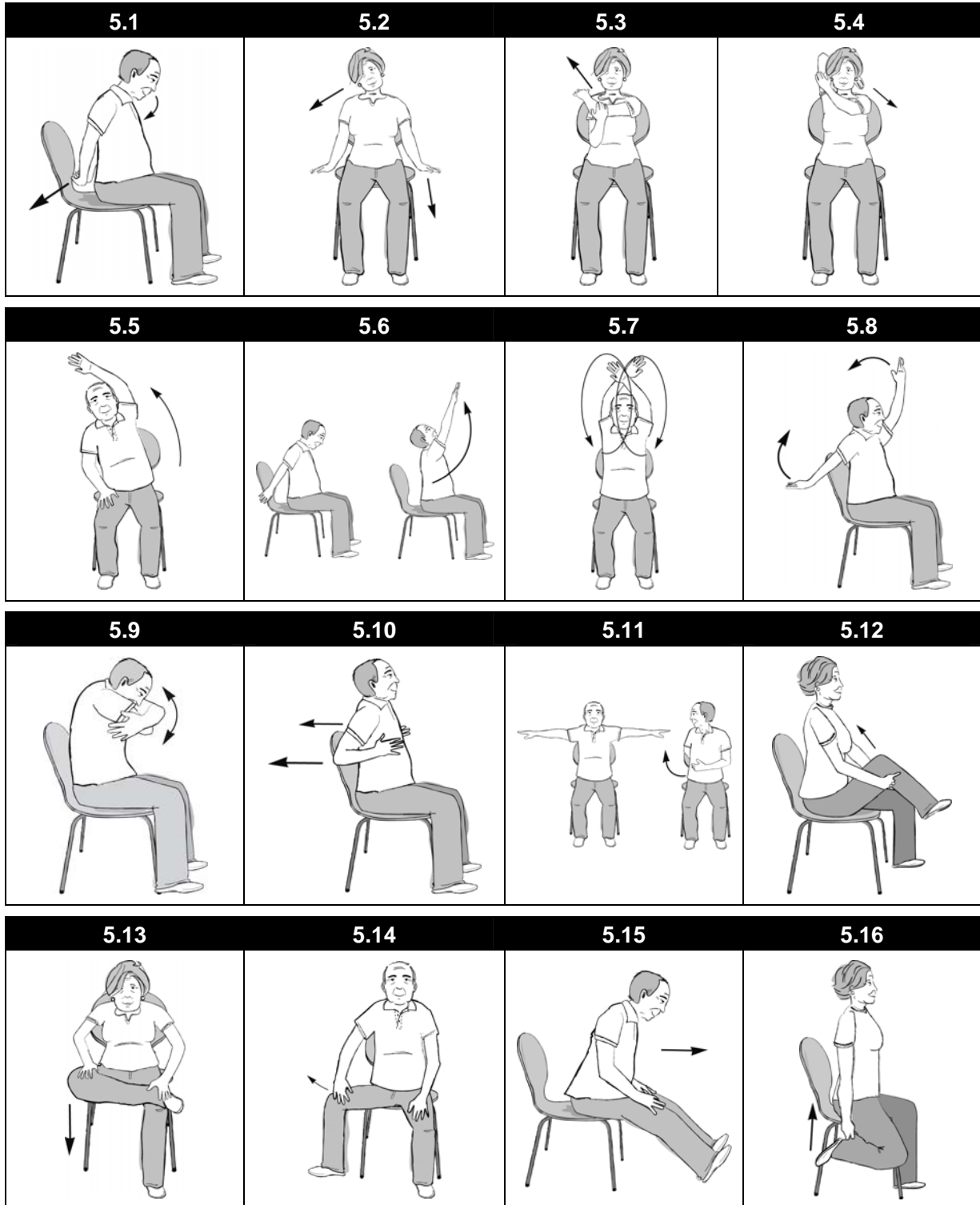

## FLEXIBILITY: BASIC MOVEMENTS

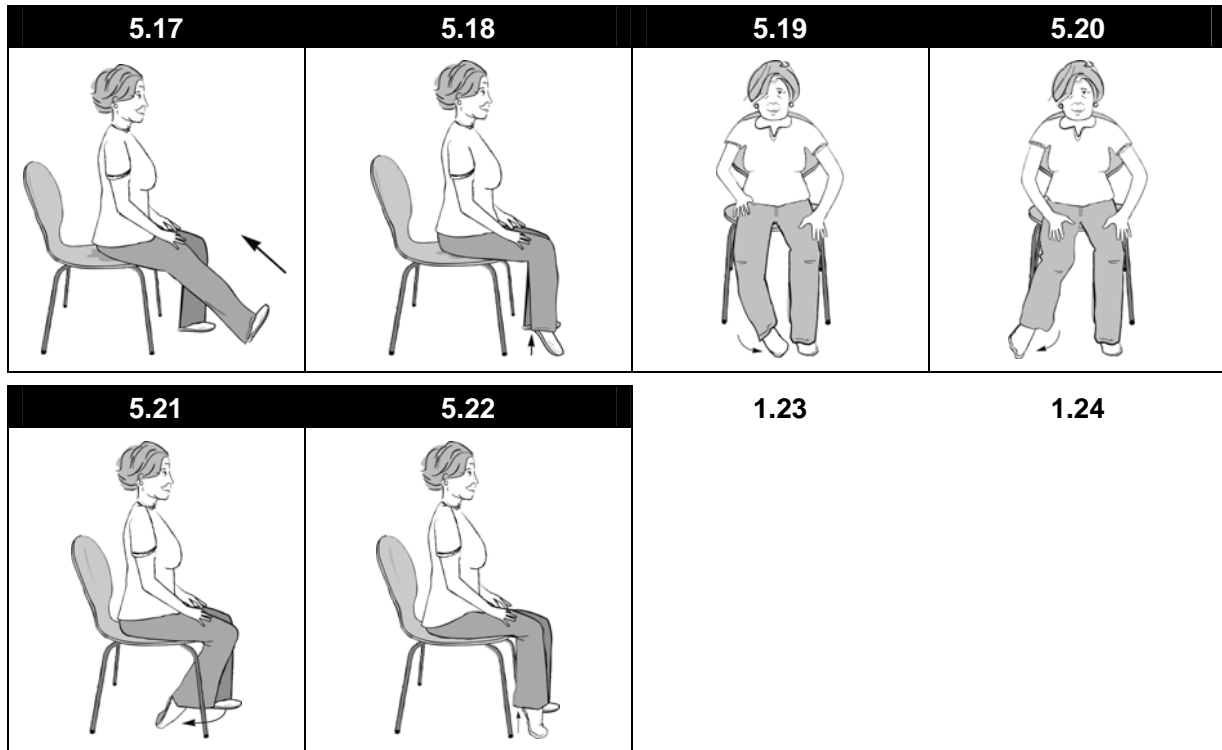

## MOVEMENT 5.1

### Exercise for

Neck.

### Starting position

- seated in the centre of the chair, back straight, head up;
- hands joined behind your back;
- feet flat on the floor, hip-width apart.



### Exercise

Bend head forward while pushing hands downward and hold the position.

### Repetition(s)

2 for 20 seconds each.

---

---

---

---

---

---

---

---

## MOVEMENT 5.2

### Exercise for

Neck.

### Starting position

- seated, back straight, lower back against chair back;
- arms by your sides, palms toward the floor, shoulders relaxed;
- feet flat on the floor, hip-width apart.

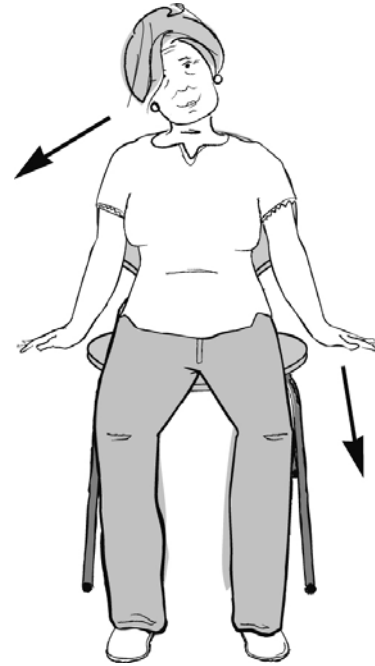

### Exercise

Keeping your chin tucked in, bend your neck to the right while pushing down with the left hand and hold position.

### Repetition(s)

2 for 20 seconds on each side.

---

---

---

---

---

---

---

---



## MOVEMENT 5.3

### Exercise for

Shoulders, arms.

### Starting position

- seated, back straight, lower back against chair back;
- left arm flexed in front of your chest, right hand supporting it near the left elbow;
- feet flat on the floor, hip-width apart.



### Exercise

Apply a gentle pressure on the left arm with your right hand and hold the position.

### Repetition(s)

2 for 20 seconds for each arm.

---

---

---

---

---

---

---

---

## MOVEMENT 5.4

### Exercise for

Arms.

### Starting position

- seated, back straight, lower back against chair back;
- right arm close to your ear, elbow flexed and pointing to the ceiling, right hand resting on upper back, left hand placed on right arm close to the elbow;
- feet flat on the floor, hip-width apart.

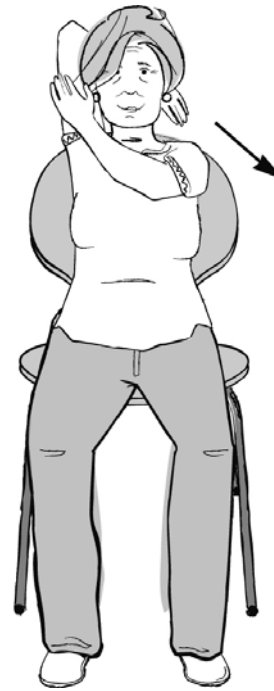

### Exercise

Apply a gentle pressure on the right arm with the left hand and hold the position.

### Repetition(s)

2 for 20 seconds for each arm.

---

---

---

---

---

---

---

---

## MOVEMENT 5.5

### Exercise for

Upper body.

### Starting position

- seated, back straight, lower back against chair back;
- left arm extended upward, right hand holding the seat or resting on your thigh;
- feet flat on the floor, hip-width apart.



### Exercise

Bend upper body to the right keeping the left arm extended and hold the position.

### Repetition(s)

2 for 20 seconds on each side.

---

---

---

---

---

---

---

---

## MOVEMENT 5.6

### Exercise for

Upper body, shoulders.

### Starting position

- seated in the centre of the chair, back straight, head dropped forward;
- arms extended backward;
- feet flat on the floor, hip-width apart.

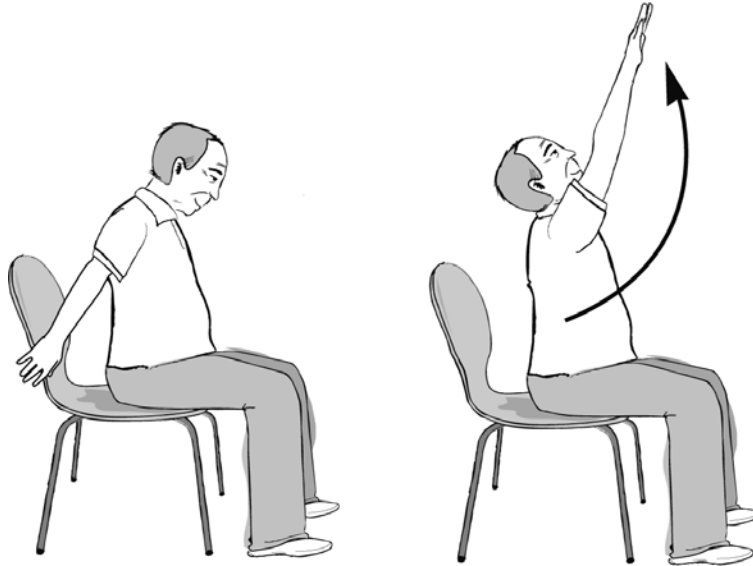

### Exercise

Inhale while raising arms forward and upward above your shoulders, stretching the upper body upward. Puff out your torso to open ribcage and raise chin slightly. Exhale as you come back to starting position.

### Repetition(s)

3.

---

---

---

---

---

---

---

---

## MOVEMENT 5.7

### Exercise for

Upper body, shoulders.

### Starting position

- seated, back straight, lower back against chair back;
- arms down by your sides;
- feet flat on the floor, hip-width apart.



### Exercise

Inhale while crossing your arms in front of you and raising them to make a big circle. Stretch torso upward and puff out to open ribcage. Exhale as you lower your arms on either side to come back to the starting position.

### Repetition(s)

3.

---

---

---

---

---

---

---

---

## MOVEMENT 5.8

### Exercise for

Chest, arms, upper body.

### Starting position

- seated, back straight;
- left arm stretched upward, right arm stretched down, palms turned backward;
- feet flat on the floor, hip-width apart.



### Exercise

Push both arms backward to direct palms toward each other and hold the position.

### Repetition(s)

2 for 20 seconds per position (alternating arm positions).

---

---

---

---

---

---

---

---

## MOVEMENT 5.9

### Exercise for

Back, neck.

### Starting position

- seated, back straight;
- arms crossed on your chest;
- feet flat on the floor, hip-width apart.



### Exercise

Round your back, bend head forward and hold the position.

### Repetition(s)

2 for 20 seconds.

---

---

---

---

---

---

---

---

## MOVEMENT 5.10

### Exercise for

Chest.

### Starting position

- seated, back straight, lower back against chair back;
- arms bent, elbows pointing backward, hands at chest level;
- feet flat on the floor, hip-width apart.

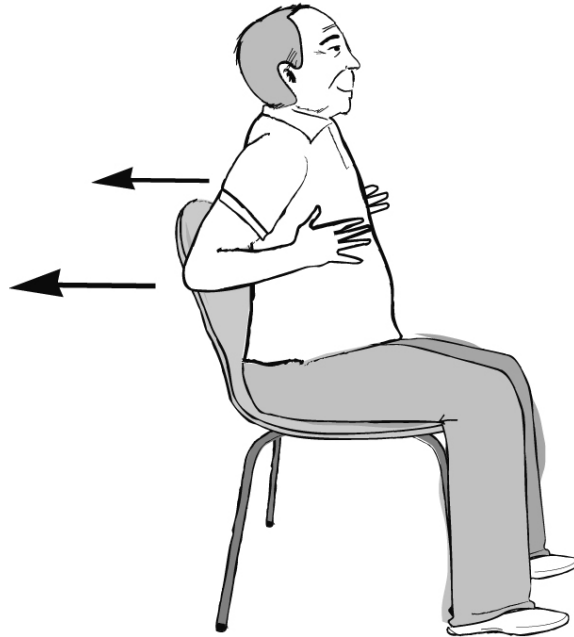

### Exercise

Push elbows back squeezing them toward one another and hold the position.

### Repetition(s)

2 for 20 seconds.

---

---

---

---

---

---

---

---



## MOVEMENT 5.11

### Exercise for

Back, chest.

### Starting position

- seated in the centre of the chair, back straight;
- arms extended to the sides at shoulder level;
- feet flat on the floor, hip-width apart.

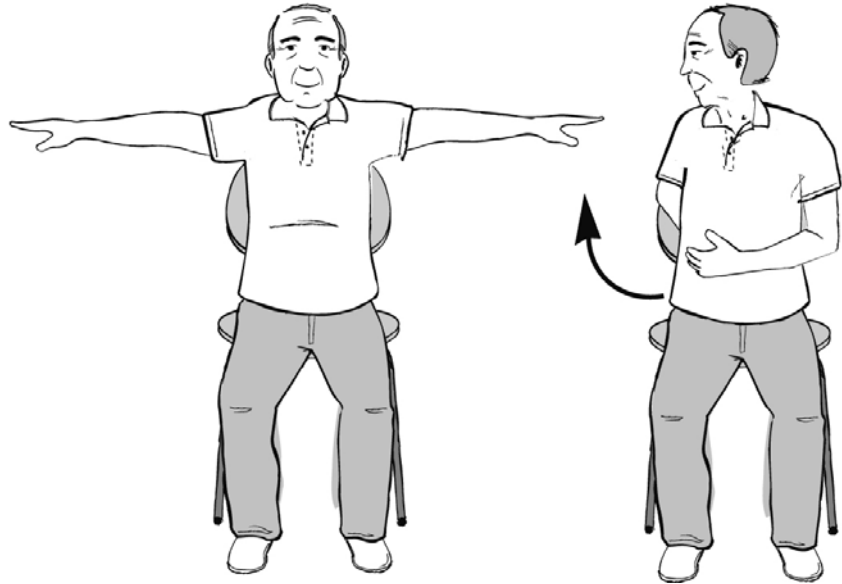

### Exercise

Turn upper body to the right, bending right arm across your back and left arm across your abdomen and hold the position. Head follows the movement of your body.

### Repetition(s)

2 for 20 seconds on each side.

---

---

---

---

---

---

---

---

## MOVEMENT 5.12

### Exercise for

Buttocks, lower back.

### Starting position

- seated, back straight, lower back against chair back;
- both hands under right thigh;
- feet hip-width apart, one foot flat on the floor and the other raised.



### Exercise

Use your hands to pull right thigh toward your chest, keeping back straight.

### Repetition(s)

2 for 20 seconds for each thigh.

---

---

---

---

---

---

---

---

## MOVEMENT 5.13

### Exercise for

Thighs, buttocks, hips.

### Starting position

- seated, back straight, lower back against chair back;
- hands resting on thighs;
- left foot flat on the floor, right ankle resting on left thigh.

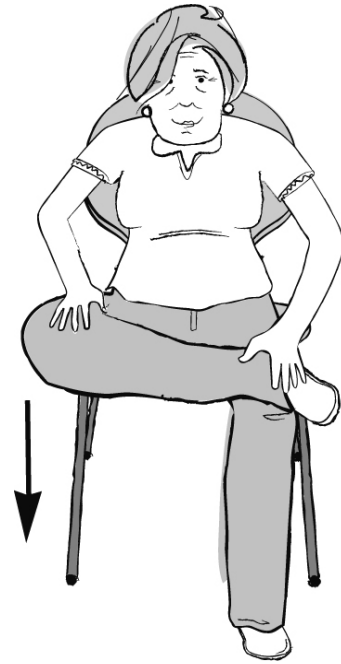

### Exercise

Bend forward from the hips, pushing right thigh down gently and hold the position.

### Repetition(s)

2 for 20 seconds for each leg.

---

---

---

---

---

---

---

---

## MOVEMENT 5.14

### Exercise for

Thighs.

### Starting position

- seated well forward on the chair, back straight;
- hands resting on thighs;
- feet flat on the floor, right leg open so that foot is on the outside of the chair leg, left leg in line with your hip.

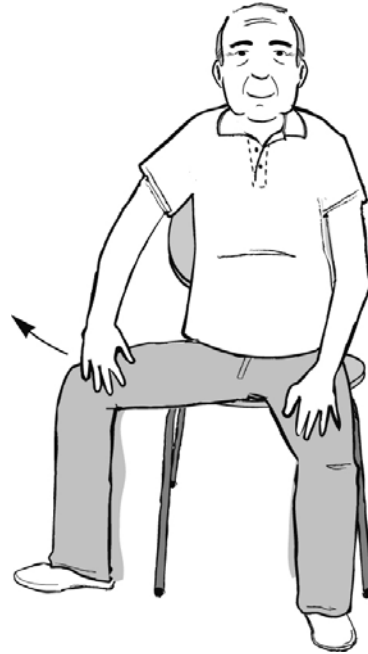

### Exercise

Gently push against inner side of right thigh with right hand and hold the position.

### Repetition(s)

2 for 20 seconds for each thigh.

---

---

---

---

---

---

---

---

---

---

## MOVEMENT 5.15

### Exercise for

Thighs.

### Starting position

- seated well forward on the chair, back straight;
- hands resting on thighs;
- legs stretched forward, hip-width apart, heels resting on the floor.



### Exercise

Bend forward slightly from the hips and hold the position.

### Repetition(s)

2 for 20 seconds.

---

---

---

---

---

---

---

---

## MOVEMENT 5.16

### Exercise for

Thighs, hips.

### Starting position

- seated on the side of the chair, back straight;
- left hand holding seat of chair and right hand grasping the end of your trousers;
- right leg bent so that knee is pointed toward the floor, left foot flat on the floor in line with your hip

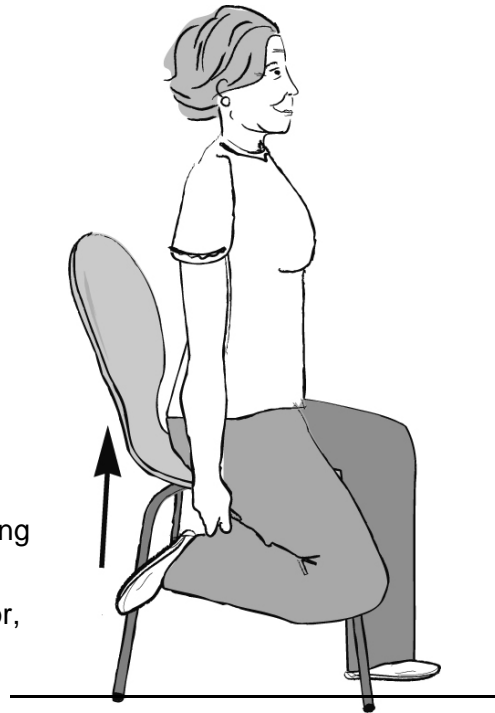

### Safety Tip

It is important to place body weight on the opposite side to the raised leg to avoid falling.

---

### Exercise

Pull right leg backward and upward while tilting your pelvis forward and contracting your abdominal muscles; hold the position.

### Repetition(s)

2 for 20 seconds for each thigh.

---

---

---

---

## MOVEMENT 5.17

### Exercise for

Legs

### Starting position

- seated in the centre of the chair, back straight;
- hands resting on thighs;
- legs hip-width apart, left foot flat on the floor, right leg straight forward, heel on the floor.

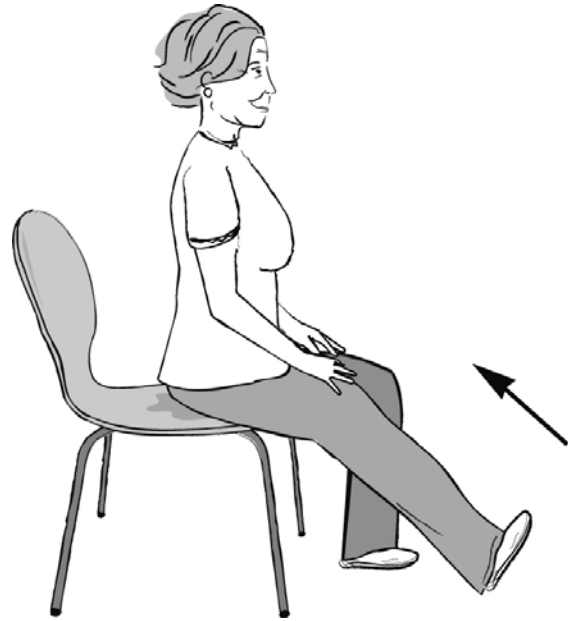

### Exercise

Flex right ankle so that toes are pointed toward the tibia and hold the position.

### Repetition(s)

2 for 20 seconds for each leg.

---

---

---

---

---

---

---

---

## MOVEMENT 5.18

### Exercise for

Legs, feet.

### Starting position

- seated in the centre of the chair, back straight;
- hands resting on thighs;
- remove shoes; legs hip-width apart, right leg slightly forward.

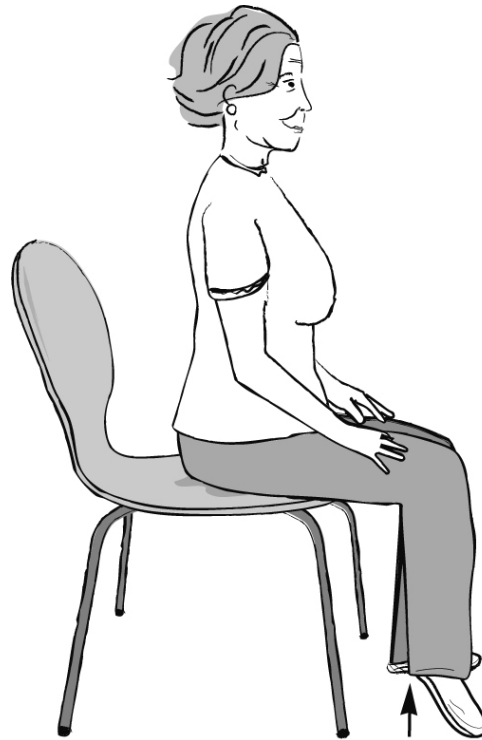

### Exercise

Point right foot, raising heel and hold the position.

### Repetition(s)

2 for 20 seconds for each leg.

---

---

---

---

---

---

---

---



## MOVEMENT 5.19

### Exercise for

Legs, feet.

### Starting position

- seated, back straight, lower back against chair back;
- hands resting on thighs;
- remove shoes; feet flat on the floor, hip-width apart.

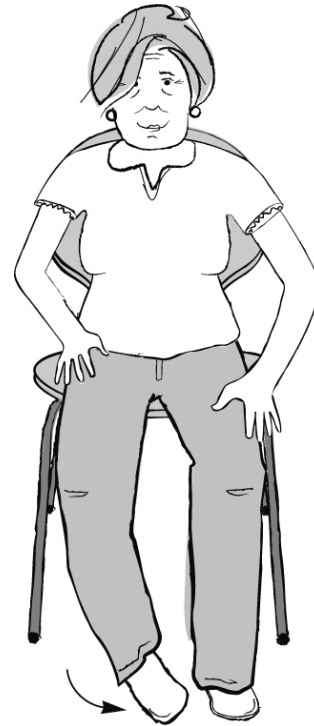

### Exercise

Raise the inner side of the right foot off the floor, outer side resting on the floor, and hold the position.

### Repetition(s)

2 for 20 seconds for each foot.

---

---

---

---

---

---

---

---

## MOVEMENT 5.20

### Exercise for

Legs, feet.

### Starting position

- seated, back straight, lower back against chair back;
- hands resting on thighs;
- remove shoes; feet flat on the floor, hip-width apart.



### Exercise

Raise outer side of right foot, inner side resting on the floor and hold the position.

### Repetition(s)

2 for 20 seconds for each foot.

---

---

---

---

---

---

---

---

## MOVEMENT 5.21

### Exercise for

Legs, feet, toes.

### Starting position

- seated in the centre of the chair, back straight;
- hands resting on thighs;
- remove shoes; legs hip-width apart, left foot flat on the floor, right foot under the chair.



### Exercise

Flex toes, pressing them gently into the floor and hold the position.

### Repetition(s)

2 for 20 seconds for each foot.

---

---

---

---

---

---

---

---

## MOVEMENT 5.22

### Exercise for

Legs, feet, toes.

### Starting position

- seated in the centre of the chair, back straight;
- hands resting on thighs;
- remove shoes; feet flat on the floor, hip-width apart.

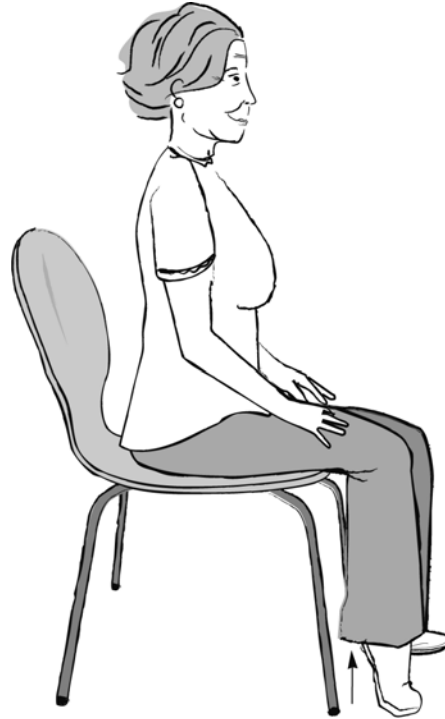

### Exercise

Raise heel and ball of the foot to flex toes and hold the position.

### Repetition(s)

2 for 20 seconds for each foot.

---

---

---

---

---

---

---

---

---

---

**Home environment**

**Section 1**

**Outside stairs**





## OUTSIDE STAIRS

---

In a new building, it is preferable not to have any stairs or levels. Stairs always create a high risk of falls, even when they are not used very often. When stairs are already there and are essential, they can be made safer.

### Here are the points to consider:

Anti-skid covering

Handrails

Same-sized steps

First and last step markers

Closed risers in a contrasting colour

Clear steps

Adequate lighting

Mailbox at the right height and not above the staircase

Safe practices

### Legend

**\$:** between \$5 and \$25

**\$\$:** between \$25 and \$50

**\$\$\$:** between \$50 and \$100

**\$\$\$\$:** more than \$100



## OUTSIDE STAIRS

### Anti-skid covering

#### Function

To ensure that the foot is securely placed on the step, especially when the weight is on one foot only. Since outside stairs are constantly exposed to changing weather conditions, proper covering and maintenance of the steps are crucial.

#### Description

The anti-skid covering can be either anti-skid paint, self-adhesive abrasive strips, or rubber (thin) anti-slip strips. Porous concrete or grooved metal also make good anti-skid covering for treads.

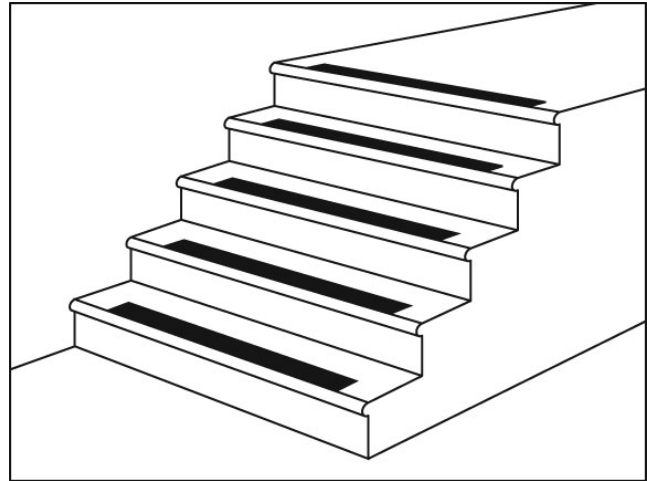

#### Dimensions

If you choose paint, it can be used on the entire surface of the step, whereas a narrow anti-skid strip about one-inch wide is often sufficient, so long as it covers at least three quarters ( $\frac{3}{4}$ ) of the width of the step.

#### Installation

The anti-skid covering can be installed by someone you know or by a workman. If you choose to use regular paint, you must sprinkle silica sand on the steps when the paint is still wet. Anti-skid paint is also effective but is decidedly more expensive. Finally, the self-adhesive abrasive or rubber anti-slip strips, so long as they are held securely in place, are probably the simplest, least expensive and most effective solution for safety and durability.



## OUTSIDE STAIRS

### Anti-skid covering

---

#### Suppliers

Hardware stores, paint stores, department stores

Approximate cost: anti-skid paint: \$\$\$/gallon (ex.: American safety)

self-adhesive anti-slip strips: \$

silica sand: \$

regular paint: \$\$

rubber strips: \$



#### Tips

- Before affixing the anti-skid covering of your choice, make sure that the steps are even (see following illustrations).
- When used frequently, treads coated with anti-skid paint can become slippery again over time; they will need more anti-skid paint or adhesive strips.
- Clear stairs regularly to avoid lessening the effect of the anti-skid covering.
- If you install outdoor carpet for the winter, make sure that you keep it in good condition and that it is firmly fastened down to each step.
- Remove snow quickly to avoid ice formation, and de-ice immediately if necessary.





## OUTSIDE STAIRS

### Handrails

#### Function

To prevent loss of balance by ensuring that the person has something solid to hold on to when going up or down the stairs. Handrails allow people to use their arms and hands when going up or down stairs, especially if their balance is poor.

#### Description

Handrails should be:

1. Solidly installed;
2. Uninterrupted, even on a landing;
3. Curved at the ends to prevent anything from catching and to indicate the end of the stairs;
4. Installed on both sides of the stairs.

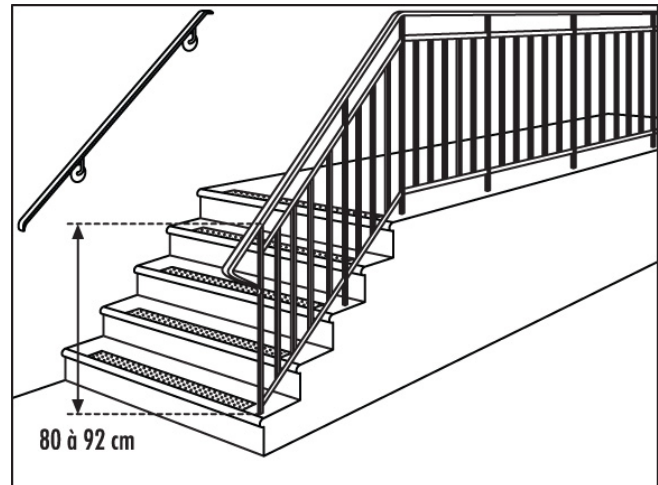

#### Dimensions

Handrails should be installed at a height of 80 to 92 cm (31 ½ to 36 ¼ inches) above the nose of the steps and extend for 30 cm (11 ¾ inches) past the beginning and the end of the stairs. They should be rounded (2.5 to 4 cm, 1 to 1 ½ inches in diameter) and be 5 cm (2 inches) from the wall for a better grip.



#### Caution!

Refer to occupational therapist if the person:

- does not have sufficient arm strength to use the handrails;
- does not feel safe using handrails;
- uses a walker or has difficulty using the stairs.



## OUTSIDE STAIRS

## Handrails

---

### Installation

When installing handrails, it is important to install them solidly.

### Suppliers

Carpenter (yellow pages of the phonebook).

Approximate cost: a carpenter will charge about: \$\$/hour

equipment: price varies depending on materials chosen.



### Tips

- Always use the handrails when going up and down the stairs.
- Carry objects in a bag with handles in order to always have at least one hand free to use the handrail. If necessary, do not hesitate to ask people around you to help with carrying objects



## OUTSIDE STAIRS

### Same-sized steps

#### Function

To give stable support to the feet and a certain continuity of movement (encoding of information in the brain), with respect to the height and placement of the steps.

#### Description

All the steps should be identical in height and depth. For all staircases, it is recommended that you have a minimum of three risers and a maximum of ten steps between landings. The stairs should be in good condition and safe, i.e. the following should not be found: snow or ice; broken, unstable or sloping steps; raised metal edges; raised or missing tiles; loose carpeting; worn concrete; rounded treads, etc.

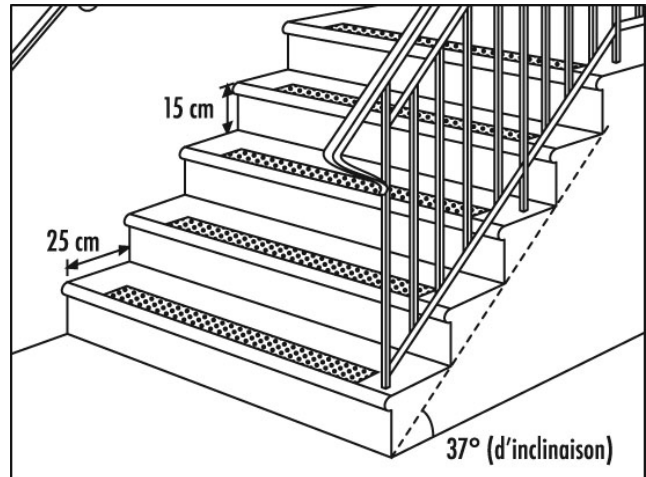

#### Dimensions

The incline of the stairs should be equal to or less than 37°; the depth of each step should be equal to or more than 25 cm (10 inches) and the riser should be no higher than 15 cm (7 inches). The nose of each step should not extend more than 2.5 cm (1 inch) beyond the step and should be rounded or beveled.



#### Caution!

##### Refer to occupational therapist if the person:

- has moderate to severe coordination problems; same-sized steps will not improve the situation.



## OUTSIDE STAIRS

### Same-sized steps

---

#### Installation

The right professional to repair the steps depends on what the stairs are made of (ex.: if the stairs are wooden, a carpenter will do the repairs).

Carpenter (yellow pages of the phonebook).

Approximate cost: depending on the materials and the professional, (a carpenter will charge about \$\$/ hour).

#### Suppliers

Carpenter (yellow pages of the phonebook).

Approximate cost: depending on the materials and the professional (a carpenter: \$\$/ hour).



#### Tips

- Use of coarse salt in winter can cause concrete steps to wear down prematurely. Opt for a product that does not attack the concrete, such as gravel, sand or ashes.
- Clear snow from the stairs regularly during the winter. A shelter can also prevent snow accumulation and ice formation. However, if there is already ice on the steps, spread coarse salt to remove it (except on concrete stairs) or use gravel, ashes or sand for a better grip.
- Have steps repaired when necessary.



## OUTSIDE STAIRS

## First and last step markers

### Function

To enable the person to clearly see the beginning and end of the staircase.

### Description

Preferably an anti-skid paint in a contrasting colour or, if you don't have this, a contrasting-coloured adhesive strip on the first and last tread. The adhesive strip should be changed frequently as it wears out, or if the edges start to come loose.

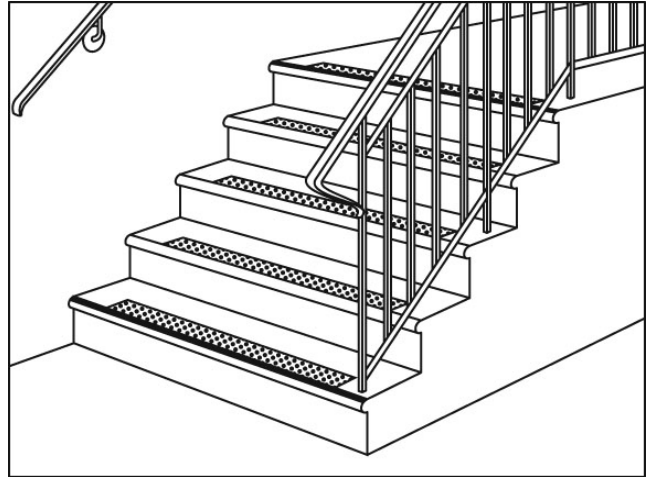

### Dimensions

The marker usually covers the entire width of the tread.



### Caution!

#### Refer to occupational therapist if:

- the client's vision is inadequate and the markers installed do not enable them to see clearly the start and the end of the stairs.



## OUTSIDE STAIRS

## First and last step markers

---

### Suppliers

Hardware stores

Approximate cost: anti-skid paint (paint containing sand): \$\$

Adhesive tape: \$



### Tips

- The nose of each step can also be clearly identified with contrasting-colour, especially for persons having severe visual perception problems.



## OUTSIDE STAIRS

### Closed risers in a contrasting colour

#### Function

To ensure that the foot rests completely on the step, so that the extremity of the foot will not catch underneath the step above when the person is going up the stairs. The contrasting colour facilitates a three-dimensional perception of the steps.

#### Description

The riser should completely cover the opening created by the space between the two steps. There should be no overhanging treads (steps that extend beyond risers).

The maximum height of risers should be 18 cm (7 inches). The face of the riser should be flat. Avoid stairs without risers, so that the foot will not slip beyond the step (HASI).

#### Dimensions

Same dimensions as the space between the steps. If the person has visual perception problems, the riser can be completely painted in a contrasting colour.

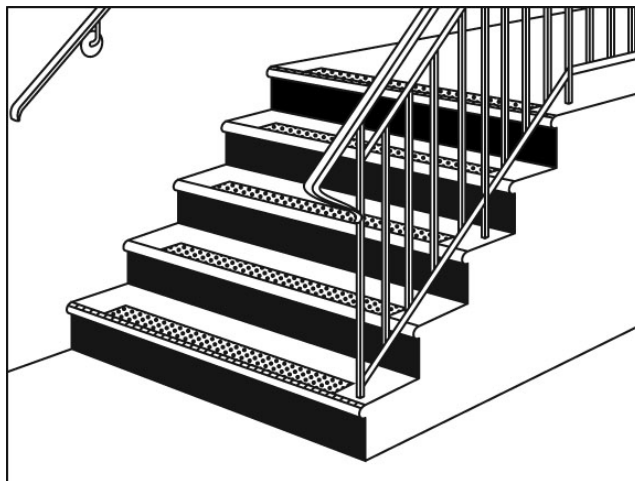



## OUTSIDE STAIRS

## Closed risers in a contrasting colour

---

### Suppliers

Hardware stores, specialty shops.

Approximate cost: paint: \$/quart

wood: varies according to the number of risers to be covered

carpenter: \$\$/hour



### Tips

- If the work is too expensive and the person's income is insufficient, check for admissibility to the Société d'habitation du Québec Home Adaptations for Seniors' Independence (HASI) program.
- Depending on the location of the stairs and the angle of the steps, make sure that water cannot accumulate on them, to avoid icing during the winter.





## OUTSIDE STAIRS

### Clear steps

#### Function

All steps, stairs and landings should always be kept clear to avoid tripping, stumbling or slipping.

#### Description

People are often in the habit of leaving things on the stairs, either because of lack of storage space, or to avoid having to walk. For example, stepping on a sheet of paper can make you slip and fall.

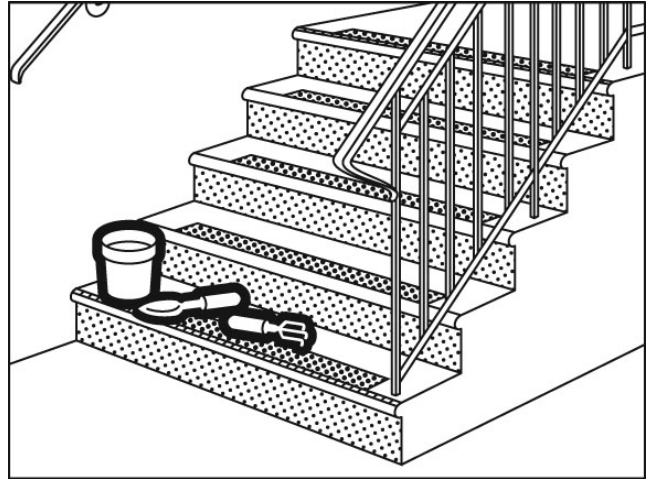

#### Tips

- Explain clearly to the other residents of the house the importance of not leaving objects on the stairs.
- To avoid unnecessary going up or down stairs, advise the person to place objects in a strategic spot and to put them away as soon as possible, for example in a bag hung on a hook near the stairs.





## OUTSIDE STAIRS

### Adequate lighting

#### Function

To illuminate the stairs without creating shadowy spots. To enable the person to clearly see the edge and the depth of the steps.

#### Description

Lighting should be intense without being blinding. Ideally, there should be a motion detector that causes the light to go on when somebody is close to the stairs, or a photosensitive device that makes the light go on when there is insufficient natural light.

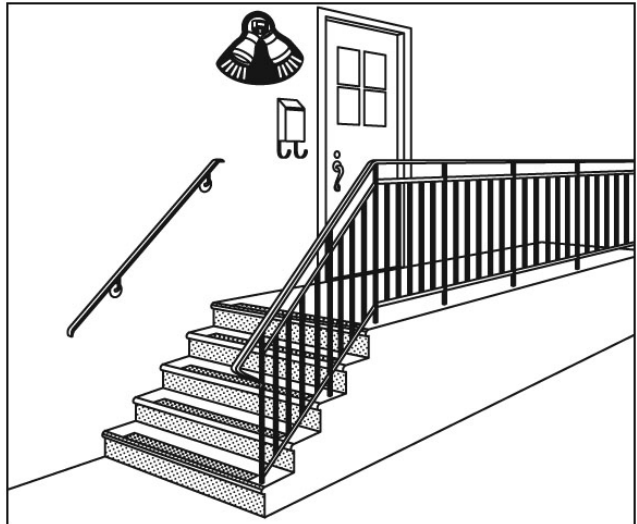

#### Dimensions

Variable according to the space to be lit and the type of light chosen.



#### Caution!

##### Refer to occupational therapist if:

- The person's vision, even with good lighting, does not seem to be adequate to ensure safety on the stairs.
- Check whether the person has had his vision checked recently and make a referral if needed (see screening for visual disorders).



## OUTSIDE STAIRS

### Adequate lighting

---

#### Installation

Electrical outlets should be installed by an electrician.

#### Suppliers

Hardware stores, electricians (yellow pages of the phonebook).

Approximate cost: \$ (100-watt or halogen bulb)

to install one electrical outlet: between \$\$ and \$\$\$\$

to install one electrical switch: \$\$



#### Tips

- Change bulbs as soon as they burn out.
- Opt for lights fitted with a motion detector or that come on automatically when the natural light is insufficient (photosensitive).



## OUTSIDE STAIRS

## Mailbox at the right height and not above the stairs

### Function

To make “getting the mail” as safe as possible. Prevents the person from having to do two things at the same time (for example, pick up the mail and go down the stairs).

### Description

The mailbox should ideally be located near the front door, but not above the stairs. It should also be located at a functional height so that the person will not have any difficulty taking out the mail. The mailbox should be big enough to hold all the mail so that it will not overflow onto the ground.

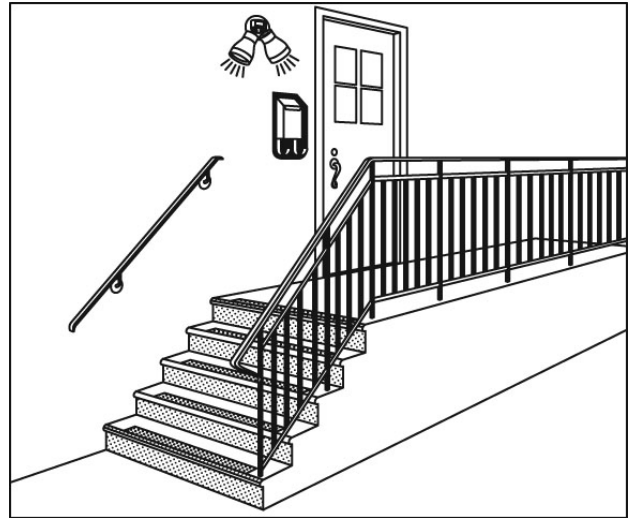

### Height

The suggested height is about that of the person's elbow when he or she is standing close to the wall.



### Caution!

#### Refer to occupational therapist:

- If the person cannot collect the mail because of some other limitation, even if the suggested height should normally allow persons with shoulder joint problems to pick up the mail.



## OUTSIDE STAIRS

## Mailbox at the right height and not above the stairs

---



### Tips

- Pick up the mail daily to avoid having it accumulate in the mailbox, as this can make it overflow on to the ground.



## OUTSIDE STAIRS

### Safe practices

---

- Clear steps and balconies of all objects, avoid clutter.
- Always have at least one hand free to hold the handrail when going up or down the stairs. Carry objects in bags with handles.
- Clear snow regularly from the stairs during winter or have someone do it for you (a shelter can avoid this operation).
- Spread coarse salt (except on concrete stairs), ashes or sand on icy surfaces during the winter.
- Go up and down the stairs slowly.
- Have stairs, ramps and balconies repaired when necessary.
- Always use the handrail.
- Wear good anti-skid shoes. Some overshoes provide a very good grip.
- If needed, use a cane with an ice pick in winter for walking outside.
- Avoid being distracted by things around you when using the stairs.
- Avoid carrying heavy or cumbersome packages that may obstruct your view when going up or down stairs.
- Ask for help if you need it to carry objects up or down stairs; have your groceries delivered, for example.
- Remove your reading glasses before using stairs. If you have bifocal glasses, be very careful on the stairs.





## Section 2

### Inside stairs





## INSIDE STAIRS

---

In a new building, it is preferable not to have any stairs or levels. Stairs always create a high risk of falls, even when they are not used very often. When stairs are already there and are essential, they can be made safer.

### **Here are the points to consider:**

Anti-skid covering

Handrails

Same-sized steps

First and last step markers

Closed risers in a contrasting colour

Clear steps

Door opening inward

Safe practices

### **Legend**

\$: between \$5 and \$25

\$\$: between \$25 and \$50

\$\$\$: between \$50 and \$100

\$\$\$\$: more than \$100



## INSIDE STAIRS

### Anti-skid covering

#### Function

To ensure that the foot is securely placed on the step, especially when the weight is on one foot only.

#### Description

The anti-skid covering can be either anti-skid paint, self-adhesive abrasive strips, or rubber (thin) anti-slip strips. Porous concrete or grooved metal can also provide good anti-skid covering for treads.

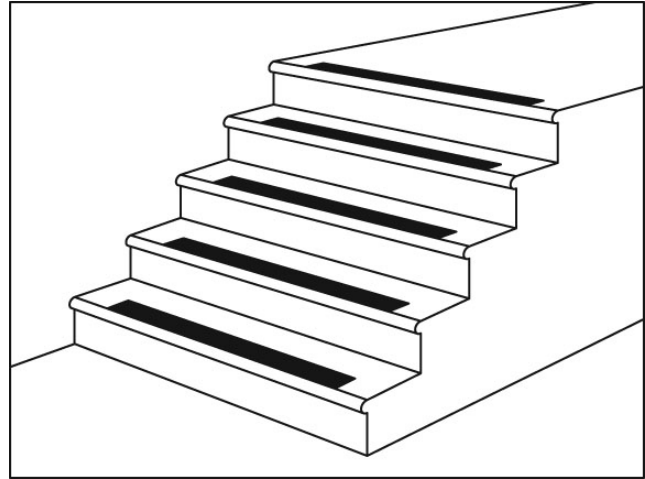

#### Dimensions

If you choose paint, it can be used on the entire surface of the tread, whereas a narrow anti-skid strip about one-inch wide is often sufficient, so long as it covers at least three quarters ( $\frac{3}{4}$ ) of the width of the tread.

### Installation

The anti-skid covering can be installed by someone you know or by a workman. If you choose to use regular paint, you must sprinkle silica sand on the steps when the paint is still wet. Anti-skid paint is also effective but is decidedly more expensive. Finally, the self-adhesive abrasive or rubber anti-slip strips, so long as they are always held securely in place, are probably the simplest, least expensive and most effective solution for safety and durability.



## INSIDE STAIRS

### Anti-skid covering

---

### Suppliers

Hardware stores, paint stores, department stores.

Approximate cost: anti-skid paint: \$\$\$/gallon (ex.: American Safety)

self-adhesive anti-slip strips: \$

silica sand: \$

regular paint: \$\$

rubber strips: \$



### Tips

- Before affixing the anti-skid covering of your choice, make sure that the steps are even (see following fact-sheet).
- When used frequently, treads coated with anti-skid paint can become slippery again over time, so you will have to make them non-skid once more with either anti-skid paint or adhesive strips.
- If you have carpet on the stairs, make sure that it is firmly fastened down to each step, or remove it.



## INSIDE STAIRS

## Handrails

### Function

To prevent loss of balance by ensuring that the person has a solid grip when going up or down the stairs. Handrails allow people to use their hands and arms when going up or down the stairs, especially if their balance is not very good.

### Description

Handrails should be: **80 to 92 cm**

1. Solidly installed;
2. Uninterrupted, even on a landing;
3. Curved at the ends to prevent anything from catching in them and to indicate the end of the stairs;
4. Installed on both sides of the stairs

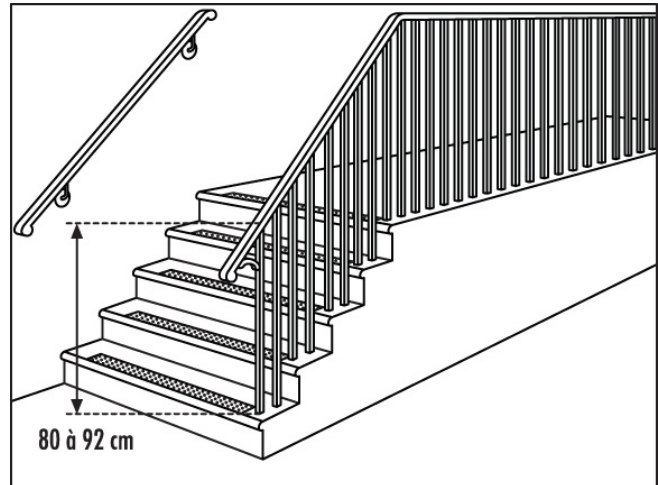

### Dimensions

Handrails should be installed at a height of 80 to 92 cm (31 ½ to 36 ¼ inches) above the nose of the steps and extend for 30 cm (11 ¾ inches) past the beginning and the end of the stairs. They should be rounded (2.5 to 4 cm, 1 to 1 ½ inches in diameter) and be 5 cm (2 inches) from the wall for a better grip.



### Caution!

Refer to occupational therapist if the person:

- does not have sufficient arm strength to use the handrails;
- does not feel safe using handrails;
- uses a walker or has difficulty using the stairs.



## INSIDE STAIRS

## Handrails

---

### Installation

When installing handrails, it is important to install them solidly.

### Suppliers

Carpenter (yellow pages of the phonebook).

Approximate cost: a carpenter will charge about: \$\$/hour  
equipment: price varies depending on materials chosen.



### Tips

- Use the handrails when going up and down the stairs.
- Carry objects in a bag with handles in order to always have one hand free to use the handrail. If necessary, do not hesitate to ask people around you to help with carrying objects.



## INSIDE STAIRS

### Same-sized steps

#### Function

37° (incline)

To give stable support to the feet and a certain continuity of movement (encoding of information in the brain), with respect to the height and placement of the steps.

#### Description

All the steps should be identical in height and depth. For all staircases, it is recommended that you have a minimum of three risers and a maximum of ten steps between landings. The stairs should be in good condition and safe, i.e. the following should not be found: broken, unstable or sloping steps; raised metal edges; raised or missing tiles; loose carpeting; worn concrete; uneven surfaces, etc.

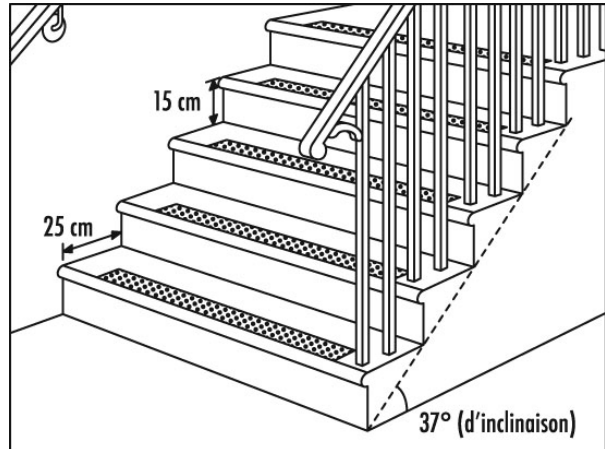

#### Dimensions

The incline of the stairs should be equal to or less than 37°; the depth of each step should be equal to or more than 25 cm (10 inches) and the riser should be no higher than 15 cm (7 inches). The nose of each step should not extend more than 2.5 cm (1 inch) beyond the step and should be rounded or beveled.



#### Caution!

Refer to occupational therapist if the person:

- has moderate to severe coordination problems; same-sized steps will not improve the situation.



## INSIDE STAIRS

### Same-sized steps

---

#### Installation

The right professional to repair the steps depends on what the stairs are made of (ex.: if the stairs are wooden, a carpenter will do the repairs).

Carpenter (yellow pages of the phonebook).

Approximate cost: depending on the materials and the professional, (a carpenter about \$\$/hour).

#### Suppliers

Carpenter (yellow pages of the phonebook).

Approximate cost: depending on the materials and the professional (a carpenter: \$\$/hour).



#### Tips

- Have steps repaired when necessary.





## INSIDE STAIRS

### First and last step markers

#### Function

To enable the person to clearly see and indicate the beginning and end of the staircase.

#### Description

Preferably an anti-skid paint in a contrasting colour or, if you don't have this, a contrasting-coloured adhesive strip on the first and last tread. The adhesive strip should be changed frequently as it wears out, or if the edges start to come loose.

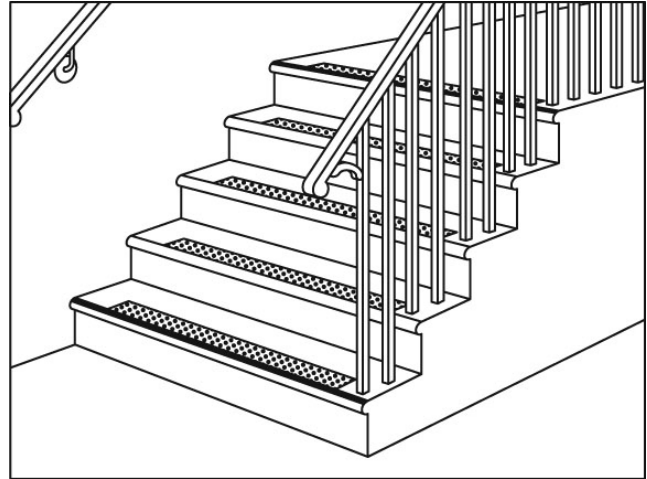

#### Dimensions

The visual marker usually covers the entire width of the tread.



#### Caution!

##### Refer to occupational therapist if:

- The client's vision is inadequate and the markers installed do not enable them to see clearly the start and the end of the stairs.



## INSIDE STAIRS

### First and last step markers

---

#### Suppliers

Hardware stores.

Approximate cost: adhesive tape: \$

anti-skid paint (paint containing sand): \$\$



#### Tips

- The nose of each step can also be clearly marked with a contrasting-colour, especially for persons having severe visual perception problems.



## INSIDE STAIRS

## Closed risers in a contrasting colour

### Function

To ensure that the foot rests completely on the step, so that the extremity of the foot will not catch underneath the step above when the person is going up the stairs. The contrasting colour allows a three-dimensional perception of the steps.

### Description

The riser should completely cover the opening created by the space between the two steps. There should be no overhanging treads (steps that extend beyond risers).

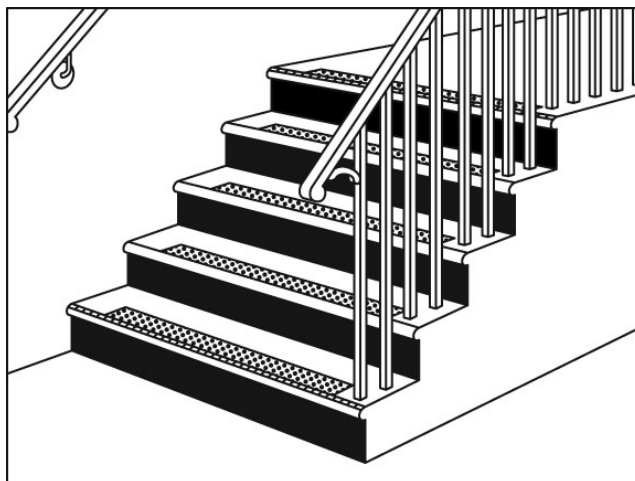

The maximum height of risers should be 18 cm (7 inches). The face of the riser should be flat. Avoid stairs without risers, so that the foot will not slip beyond the step (HASI).

### Dimensions

Same dimensions as the space between the steps. If the person has visual perception problems, the riser can be completely painted in a contrasting colour.

## Suppliers

Hardware stores, specialty shops (construction materials).

Approximate cost: paint: \$/quart

wood: varies according to the number of risers to be covered

carpenter: \$\$/hour.



## INSIDE STAIRS

## Closed risers in a contrasting colour

---



### Tips

- If the work is too expensive and the person's income is insufficient, check for admissibility to the Société d'habitation du Québec Home Adaptations for Seniors' Independence program (HASI).



## INSIDE STAIRS

### Clear steps

#### Function

All steps, stairs and upper and lower landings should always be kept clear of any objects, to avoid tripping, stumbling or slipping.

#### Description

People are often in the habit of leaving things on the stairs, either because of lack of storage space, or to avoid having to walk. For example, stepping on a sheet of paper can make you slip and fall.

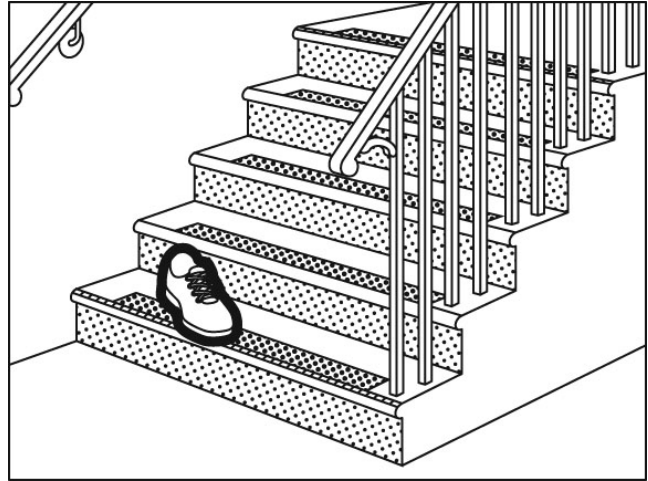

#### Tips

- Explain clearly to the other residents of the house the importance of not leaving things on the stairs.
- To avoid unnecessary going up or down stairs, place objects in a strategic spot and put them away as soon as possible, for example in a bag hung on a hook near the stairs.





## INSIDE STAIRS

### Door opening inward

#### Function

To facilitate opening and closing of the door, while avoiding unnecessary movement on the stairs.

#### Description

The door should open into the room rather than outward toward the stairs.

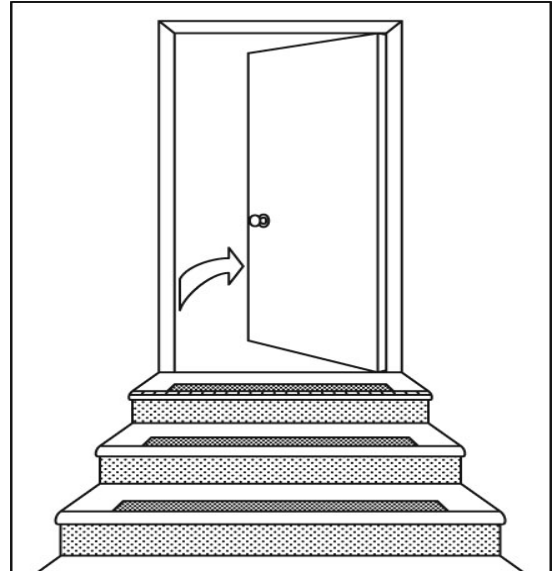

#### Installation

Reverse the hinges so the door will open on the correct side.

#### Suppliers

Carpenter (yellow pages of the phonebook).

Approximate cost: carpenter \$\$/hour



#### Caution!

Refer to occupational therapist if:

- The person has difficulty opening the door because of a dexterity problem.







## **INSIDE STAIRS**

### **Safe practices**

---

- Clear steps and landings of all objects, avoid clutter.
- Always have at least one hand free to hold the handrail when going up or down the stairs. Carry objects in bags with handles.
- Remove from the wall of the staircase any object that could distract the person's vision or make movement difficult (pictures, small shelves).
- Go up and down the stairs slowly.
- Have stairs, ramps and landings repaired when necessary.
- Always use handrails.
- Wear good anti-skid shoes.
- Use a cane if necessary to go up and down the stairs.
- Avoid being distracted by things around you when using the stairs.
- Avoid carrying heavy or cumbersome packages that may obstruct your view when going up or down stairs.
- Ask for help if you need it to carry objects up or down stairs; have your groceries delivered, for example.
- Remove your reading glasses before using stairs. If you have bifocal glasses, be very careful on the stairs.



## Section 3

# Bathroom





## BATHROOM

---

### Here are the points to consider:

Bathtub of standard height and size

Strong anti-slip grab bars

Anti-skid bathmat

Anti-skid floor mat

Accessible handheld shower

Easy-to-use bathtub plug

Accessible washbasin

Safe toilet

Accessible storage space

Safe practices

### Legend

\$: between \$5 and \$25

\$\$: between \$25 and \$50

\$\$\$: between \$50 and \$100

\$\$\$\$: more than \$100



## BATHROOM

### Bathtub of standard height and size

#### Function

To facilitate getting in and out of the bathtub.

#### Description

A non-standard bathtub (podium, free-standing, whirlpool) or sliding doors can cause problems if, for example, the bathtub is too high and the person has difficulty stepping over the side of the tub.

Sometimes, if the person needs specific equipment, a non-standard bathtub can impede its use.

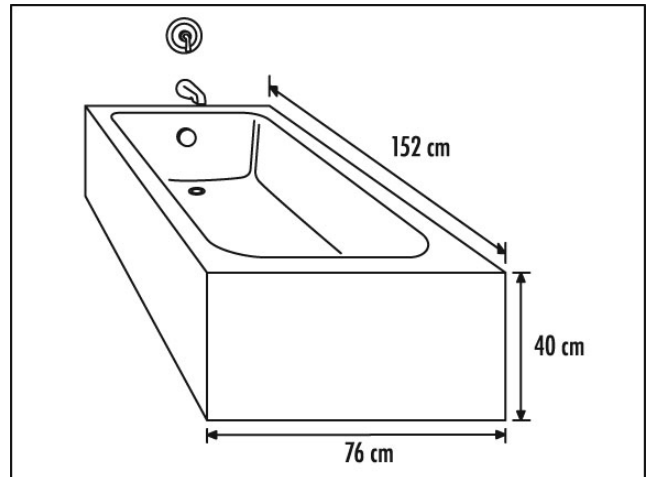

#### Dimensions

Measurements of a standard bathtub:

Height: 40 cm (15 ¾ inches)

Length: 152 cm (60 inches)

Width: 65 cm (30 inches)



#### Caution!

Refer to occupational therapist if:

- Even with a standard bathtub the client is unable to step over the side.



## BATHROOM

### Bathtub of standard height and size

---

#### Installation

Standard bathtubs should be installed by a plumber.

#### Suppliers

Plumbers: (yellow pages of the phonebook)

Approximate cost: bathtub: \$\$\$\$

installation: \$\$\$\$



#### Tips

- If the person has difficulty seeing the sides and the bottom of the bathtub, recommend sticking a coloured adhesive tape inside the edges of the bathtub.



## BATHROOM

### Strong anti-slip grab bars

#### 1. Strong vertical wall grab bar

##### Function

A vertical bar gives support to the person stepping over the side of the bathtub or shower and enables them to keep their balance.

##### Description

The surface of the bar should be grooved to give a better grip. Bars come in stainless steel, aluminum or plastic and in a variety of shapes, sizes and colours.

##### Dimensions

The recommended length is 45 cm (18 inches). The person's weight should determine the choice of material of the bar, to ensure that it is strong enough. The diameter of the bar should be in proportion to the size of the person's hands (try it out), but a diameter of 3 to 4 cm (1 ¼ to 1 5/8 inches) usually works.

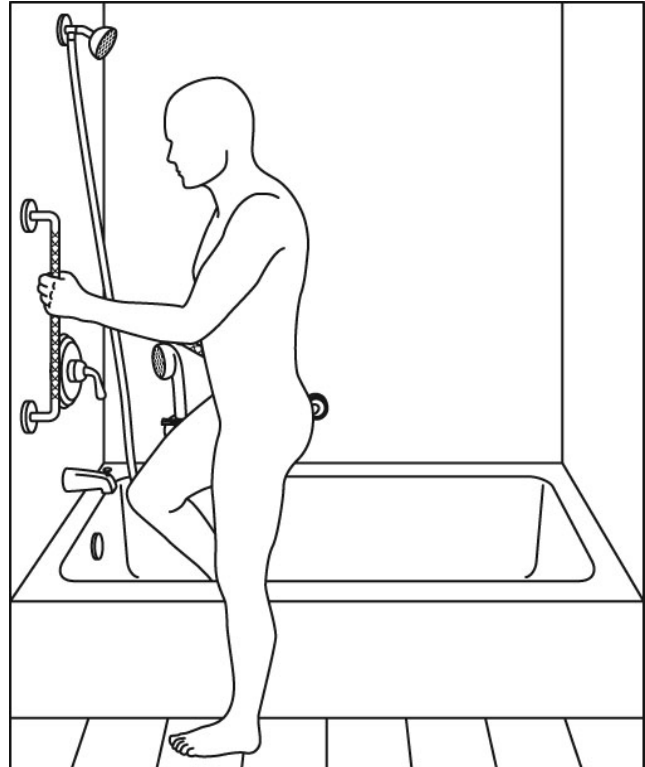

#### Caution!

##### Refer to occupational therapist if:

- The person cannot step over the side of the bathtub, even with a wall grab bar, or does so in an unsafe manner.



## BATHROOM

### Strong anti-slip grab bars

---

#### Installation

- The middle of the vertical bar should be at the height of the person's hand when standing outside of the bathtub with elbow bent at about 80 degrees, or the top of the bar should be at shoulder level. The bar is generally installed on the same wall as the faucets or soap dish.
- Since the grab bar must be able to support your weight and resist the strongest pull you can exert on it, it must be solidly attached to the wall, preferably to one of the wall studs. Silicone wing nuts or plugs can be used when it is impossible to attach the bar to the stud.
- The vertical grab bar should be placed in line with the middle of the outside edge of the bathtub.
- Wall studs are usually located 40.5 cm (16 inches) apart. To locate them, start by gently tapping the wall 35 or 45 cm (14 or 18 inches) from the start of the wall (or use a stud locator, or a magnet to locate the nails). You will notice a full sound when you tap against a stud in contrast to the hollow sound just beside it where there is no stud.
- Mark the location of the studs. The screws should be at least 6 cm (2 ½ inches) long to go through the wall panel (which is usually 1 cm, or a ½ inch thick), as well as the tiles, if the wall is tiled, and they must penetrate at least 1 or 2 cm (1/2 inch) into the stud. To avoid breaking ceramic tiles, the drill bit should be suitable for this type of wall covering.
- Allow no more than about 4.5 cm (1 ¾ inches) between the grab bar and the wall, so that the person's arm cannot slip behind the bar and remain stuck there.
- You should not worry about having grab bars installed on ceramic tiles: a professional can install grab bars on ceramic without damaging it.





## BATHROOM

### Strong anti-slip grab bars

#### 2. Diagonal wall grab bar

##### Function

To enable the person to get up safely from the bottom of the bath or from a technical aid such as a bath seat, bath bench or transfer seat. It is also recommended for safety reasons when the person gets washed standing up.

##### Description

The surface of the bar should be grooved or anti-slip. If you have a wall grab bar that is already installed but is not anti-slip, it is recommended that you add an adhesive rubberized strip. Bars come in stainless steel, aluminum or plastic and in a variety of shapes, sizes and colours.

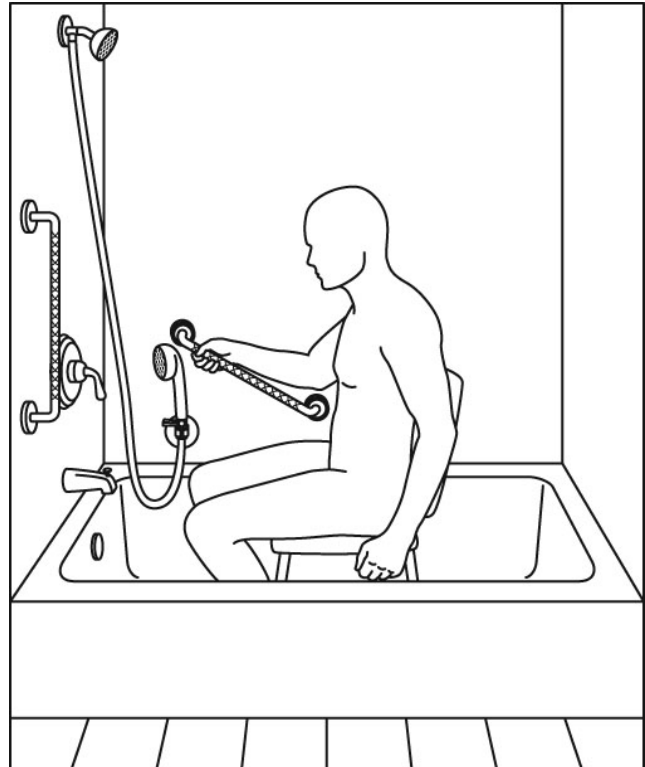

##### Dimensions

Recommended length is between 45 cm (18 inches) and 60 cm (24 inches). The person's weight should determine the choice of material of the bar, to ensure that it is strong enough. The diameter of the bar should be in proportion to the size of the person's hands (try it out), but a diameter of 3 to 4 cm (1 ¼ to 1 5/8 inches) usually works.



#### Caution!

##### Refer to occupational therapist if:

- The person has difficulty getting up from the bottom of the bath even with a diagonal bar.



## BATHROOM

### Strong anti-slip grab bars

---

#### Installation

- Similar to the installation of a vertical grab bar. However, it is attached to the side wall of the bathtub.
- Generally, the bar is installed diagonally at a 30° angle from the horizontal. The opening of the angle is toward the wall with the faucets.
- The lower end of the bar is placed at the height of the person's elbow, or between 15 cm (6 inches) and 30 cm (12 inches) from the edge of the bathtub.
- When using a bath seat or bath bench, place the bar so that the lower extremity is aligned with the centre of the seat.

#### Suppliers

Hardware stores, several department stores, orthopedic and medical centres.

Approximate cost: bar: between \$ and \$\$

anti-slip strips: \$



#### Tips

- Never use the soap dish, towel rail, faucets or shower curtain rod as a support.
- If you already have a grab bar, but it is not anti-slip, add anti-slip adhesive strips.



## BATHROOM

### Anti-skid bathmat

#### Function

To ensure that the person does not slip in the tub or shower.

#### Description

Rubber bathmats have small suction cups. They have an anti-skid surface and can be bought in contrasting colours. Don't trust tub surfaces that are supposed to be anti-skid, as they are not really effective. You can get mats that will cover up to 45.7 cm (18 inches) x 91.4 cm (36 inches).

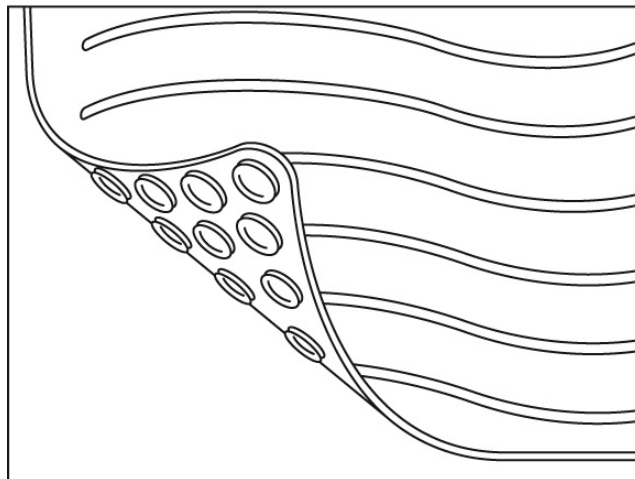

#### Installation

To make sure that the suction cups grip the bottom of the tub, wet the surface and put the mat in place. Press the mat down in 4 or 5 spots to make sure that it adheres firmly to the tub before stepping in.

#### Suppliers

Hardware stores, several department stores, orthopedic and medical centres.

Approximate cost: \$\$



## BATHROOM

### Anti-skid bathmat

---



#### Tips

- If the anti-skid mat does not completely cover the bottom of the tub, there is still a risk of falling.
- Select a mat that covers the entire surface used (some mats are too small). Replace worn mats as needed.
- Remove the mat after each use. Rinse it and let it dry on the side of the tub with the suction cups turned out. It will remain clean longer. Most mats can also be washed in the washing machine. When your mat no longer adheres to the bottom of the tub, it is time to change it.
- Avoid bath oils, use bath salts instead.



## BATHROOM

### Anti-skid floor mat

#### Function

To make sure that the person does not slip when getting out of the tub or shower.

#### Description

A mat with an anti-skid (rubber) backing.

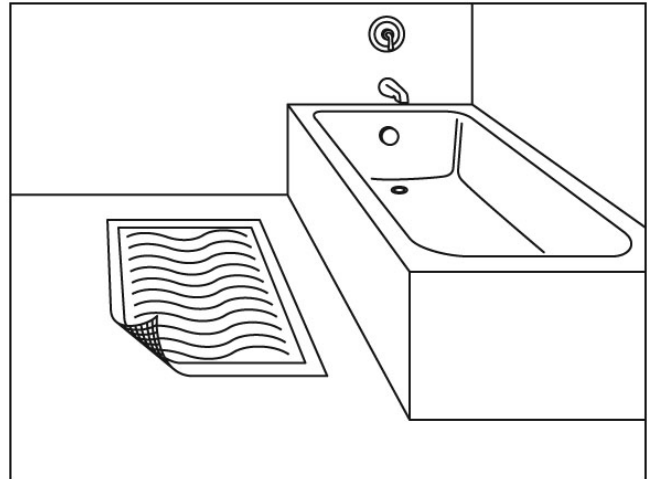

#### Suppliers

Department stores, hardware stores.

Approximate cost: floor mat: \$



#### Tips

- This mat should be removed after each use, as it can cause falls when the person is walking around the bathroom. Recommend that the person use it only for hygienic care.
- The rubber in the mat dries out over time and the mat no longer sticks to the floor. Replace the mat when it no longer sticks well.





## BATHROOM

### Accessible handheld shower

#### Function

Recommended for people who are unable to sit down in the tub. Facilitates hygienic-personal care of all parts of the body. Makes it easier to clean the tub or shower.

#### Description

A handheld shower should be composed of a shower head that is preferably equipped with a hand-operated flow control (safety catch), a swivel elbow to direct the jet, and an easily accessible wall bracket.

#### Dimensions

A hose of about 2 metres (7 feet) is recommended.

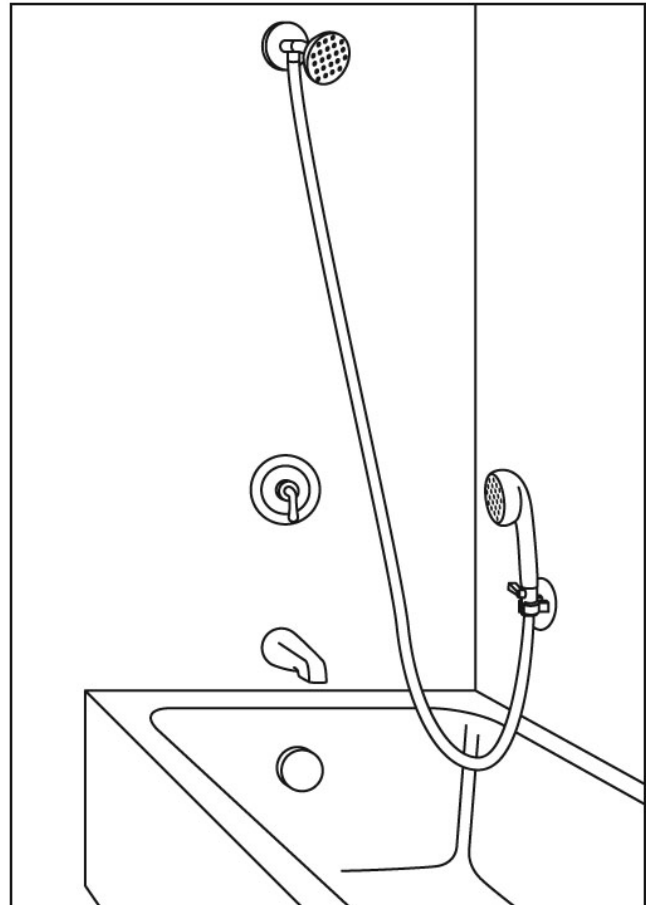

#### Installation

Install the wall bracket on the faucet wall so that the person can easily reach it. If the person is using a bath seat, bath bench or transfer seat, a wall bracket near at hand on the soap dish wall is recommended. Certain technical aids for the bath are equipped with a bracket for a handheld shower.



## BATHROOM

---

### Accessible handheld shower

#### Suppliers

Hardware stores, department stores (plumbing or specialized stores).

Approximate cost: handheld shower: \$ and \$\$



#### Tips

- It is recommended that you install a thermostatic regulator (mixing faucet) to avoid burns, especially in houses where the flow is affected by the amount of water in demand at the time, or for people who have difficulty regulating the water temperature.





## BATHROOM

### Easy-to-use bath plug

#### Function

To save the person from having to bend to put the plug in and remove it.

#### Description

Plugs are adapted to bathtub drains.

1. A pop-up (lever-operated) plug that can be opened or closed by foot or by hand.
2. A plug with a metal chain attached to it to pull it out.

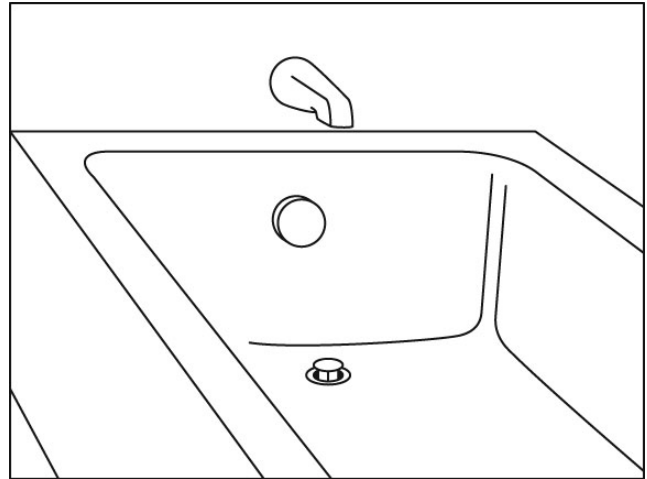

### Suppliers

Hardware stores

Approximate cost: standard plug: \$  
chain: \$  
pop-up (lever-operated) plug: about \$



#### Tips

- If possible, put one knee on the floor when manipulating the plug, to avoid losing your balance.





## BATHROOM

### Accessible washbasin

#### Function

Built-in washbasins are very common. Persons with adequate stamina and balance should be able to use the washbasin.

#### Description

There should be enough space around the washbasin to allow the person to do a partial wash without hindrance.

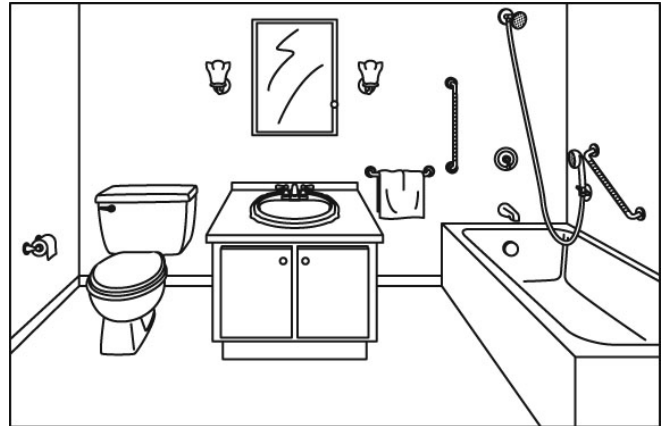

#### Dimensions

In proportion to the person's height.



#### Caution!

##### Refer to occupational therapist if:

- The person cannot remain standing for a few minutes, has balance problems or has to be seated when getting washed.





## BATHROOM

### Safe toilet

#### Function

To enable the person to sit down and get up easily. Access should be safe, i.e. the person should be able to reach the toilet quickly and easily. To facilitate hygiene and personal care after use of the toilet, it is also necessary to have sufficient space to wipe oneself, and easily accessible toilet paper.

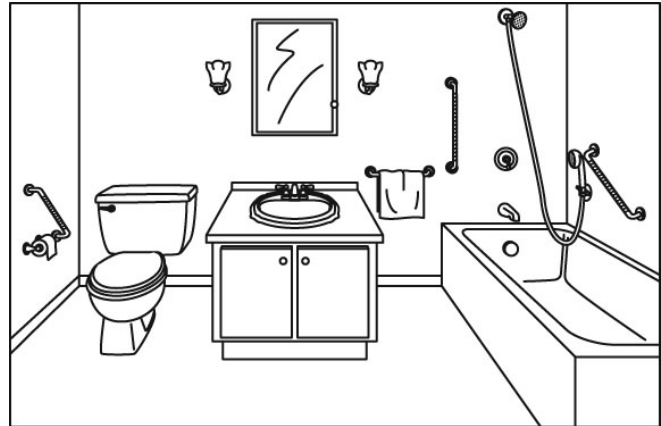

#### Description

A toilet on every floor is recommended. Ideally, the toilet should be situated close to the bedroom. The minimum height suggested is 37.5 cm (15 inches) and the person should be able to get up easily. A lateral grab bar can be installed on the wall next to the toilet, to help the person get up if the adjusted height of the toilet is not sufficient.

#### Dimensions

Sufficient space around the toilet, in proportion to the person's size, to enable them to pull pants up/down and to wipe themselves after using the toilet. The minimum distance of the toilet from the wall should be 30 cm (12 inches). Toilet paper should be 60 cm (24 inches) from the floor, 15 cm (6 inches) higher than the toilet bowl and 25 cm (10 inches) in front of it. If the height of the toilet does not allow the person to get up easily, its height can be increased in one of the following ways: preferably install a toilet 50 cm (18 inches) high or a pedestal to ensure greater stability, or add a raised toilet seat of 5, 10 or 15 cm (2 inches, 4 inches or 6 inches).



## BATHROOM

### Safe toilet

---



#### Caution!

##### Refer to occupational therapist if:

- The person has difficulty getting up without assistance, or is unable to get up; if there is insufficient space or if the person uses the toilet in an unsafe way.

## Suppliers

Hardware stores

Approximate cost: 50 cm (18 inches) toilet \$\$\$\$  
pedestal \$\$\$  
raised toilet seat \$\$\$



#### Tips

- Do not place a mat, even an anti-skid one, near the toilet.



## BATHROOM

### Accessible storage space

#### Description

Bathrooms and laundry rooms should have a place where the person can keep towels and products. This storage space should be easily accessible.

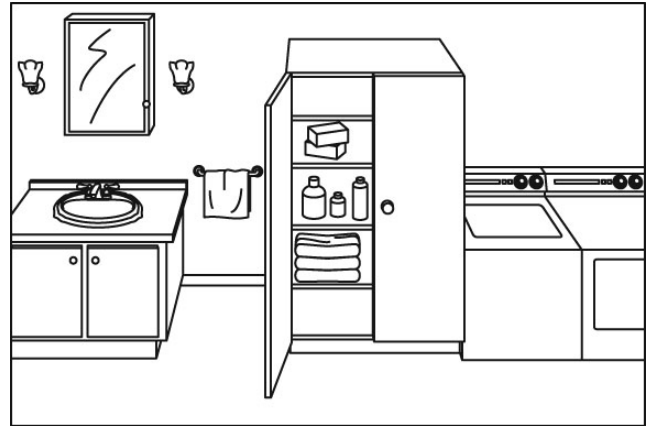

#### Dimensions

Ideally, the level of the storage space should be between the person's head and hips and it should be close to washers and dryers.



#### Caution!

##### Refer to occupational therapist if:

- Limited joint movement or muscle strength prevents the person from using the storage space.

### Installation

Installation or relocation of shelves or storage cupboards.

### Suppliers

Department stores (shelving or small cupboards) or made-to-measure by a carpenter.

Approximate cost of installation by a carpenter: \$\$ /hour.



#### Tips

- Place frequently-used objects and toiletries where they can be easily reached.







## BATHROOM

### Safe practices

---

- Place hygienic care items or toiletries (soap, shampoo, brush, towel) within easy reach.
- Use strong anti-slip grab bars for support. Do not lean on the soap dish, towel rail, faucets or shower curtain rod.
- Install a mixing faucet (thermostatic regulator) on the bath faucet to avoid burns. Check the water temperature before getting into the tub.
- Use bath salts rather than bath oil.
- Adequate lighting of the tub or shower is primordial.
- Adequate lighting can be provided by either daylight coming through the window or a good lamp that lights up the whole bathroom without creating shadowy areas. In general, a ceiling light and a light above the washbasin are recommended. The light switch should be located at the entrance to the bathroom.
- Install one or more photosensitive night lights to light the way to the bathroom during the night.
- For greater safety, bring your wireless phone with you into the bathroom.
- If you live alone and are not in good physical shape, call a relative or friend before and after your hygienic personal care.



## Section 4

# Kitchen

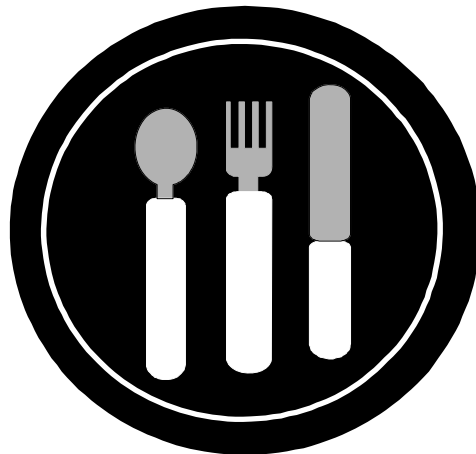



## KITCHEN

---

### Here are the points to consider:

Accessibility of frequently-used items

Accessible cupboards

Adequate work surface on the counter

Stable anti-skid step stool (if used)

Short distance between the refrigerator, stove, sink and table

Accessible electrical outlets

Solid tables and chairs

Safe practices in the kitchen

### Legend

\$ between \$5 and \$25

\$\$: between \$25 and \$50

\$\$\$: between \$50 and \$100

\$\$\$\$: more than \$100



## KITCHEN

## Accessibility of frequently-used items

### Function

Frequently-used items should be kept within easy reach. The person should not have to bend, stretch or climb to reach objects used for cooking and eating (ex.: dishes, utensils, pots, food, toaster, coffee maker, microwave oven, etc.). In short, frequently-used items should be placed so as to reduce to a minimum the need to walk or bend.



### Description

Relocate frequently-used items to more accessible places (for example, shelves within easy reach). If there is a lack of functional space, reduce the height and depth of already existing shelves that are too high, or install new shelves.

### Dimensions

Add shelves and hooks between the counter and the cupboards, 1.20 m (48 inches) from the floor. Another more costly option to consider if planning to renovate the kitchen: install the cupboards 35 cm (14 inches) instead of the usual 50 cm (18 inches) from the counter.



## KITCHEN

## Accessibility of frequently-used items

---



### Caution!

#### Refer to occupational therapist if:

- Despite relocating or adding shelves, the person cannot get at the items because of a limited range of motion in the shoulder, or because the person uses a wheelchair.

## Suppliers

Carpenter for installation: \$\$/hour

Hooks and shelves in department and hardware stores: depending on models chosen

Approximate cost of shelving varies according to the material chosen:

Carpenter: \$\$/hour

Hooks: \$



### Tips

- Inform the family about the importance of keeping frequently-used articles in easily accessible places.
- Do not use the counter for storage, as this reduces work space.



## KITCHEN

## Accessible cupboards

### Function

To avoid using cupboard shelves that are too high or deep, so that the person will not have to stretch or climb to get objects. Cupboards close to the floor can also cause falls.

### Description

Change shelving to a functional height or install turntables or sliding shelves.

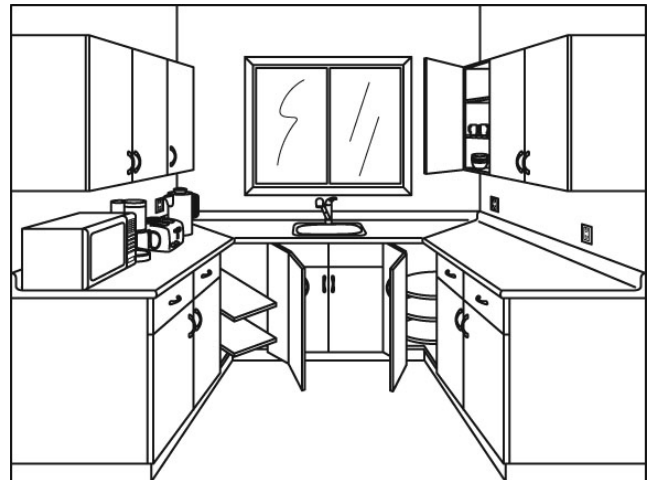

## Suppliers

Carpenter: \$\$/hour

Shelves in department stores and hardware stores.



### Tips

- It is recommended to leave cupboards above the stove empty because stretching to get something from above the stove constitutes a danger, especially when the stove is on.







## KITCHEN

### Adequate work surface on the counter

#### Function

Adequate work surface on the counter is a necessity in the kitchen, even if the person only prepares light meals. Counters are often too crowded.

#### Description

The kitchen counter can be used as a work surface when you need to stand to work. The kitchen table is the best option when you can work sitting down. If this is not possible, you can use a stool to work on the counter. Work surfaces should be well lit.



#### Tips

- If there is no work space on the counter, the person can use the kitchen table as a work surface. Advantage: the person can remain seated to work.





## KITCHEN

## Stable anti-skid step stool

### Function

Persons with balance problems should never use step stools. Even those with good balance should avoid using them and opt instead to place frequently-used articles in convenient places and increase accessible storage space (see preceding pages).

### Description

If a step stool has to be used, it should have the following features: folding, light, stable, anti-skid feet and steps, and no more than three steps. Step stools with a hand rail are recommended as they give better support.

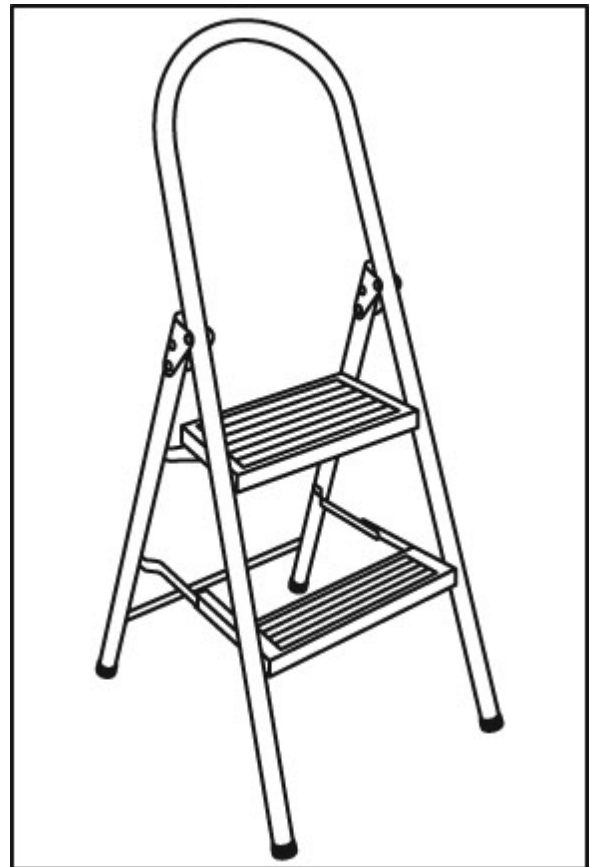

### Suppliers

Hardware stores, department stores.

Approximate cost: good step stool: \$\$



## KITCHEN

## Stable anti-skid step stool

---



### Caution!

#### Refer to occupational therapist if:

- The person has balance problems and functional storage space cannot be increased.



### Tips

- Move frequently-used items instead of using a step stool.
- Avoid tilting your head backward when you are on a step stool. This can cause a sudden loss of balance without any warning sign.



## KITCHEN

### Short distance between the refrigerator, stove, sink and table

#### Function

To avoid walking medium or long distances with hot objects or heavy items such as pots filled with water. Ideally, heavy or hot objects should be slid along the counter.

#### Description

If the layout of the kitchen is not functional, a serving trolley can be used to transport objects.

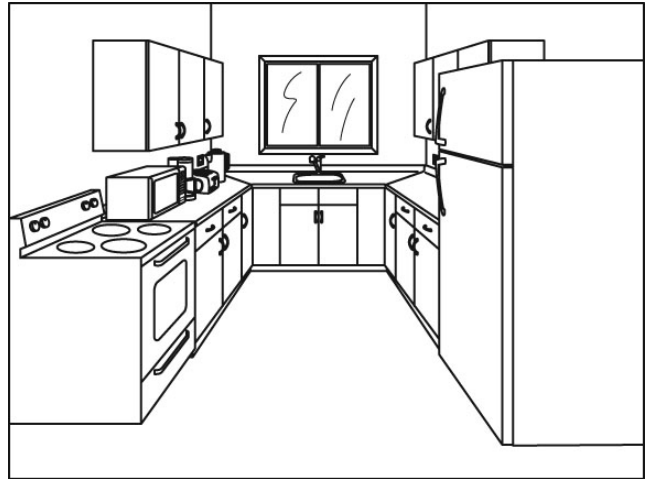

#### Suppliers

Specialized equipment stores or department stores.

Approximate cost: serving trolley: \$\$\$



#### Tips

- Certain objects used at every meal can be left on the kitchen table to reduce walking at mealtimes.





## KITCHEN

## Accessible electrical outlets

### Function

Outlets should be located near work surfaces, so that the person will not need to bend or stretch to plug in appliances.

### Description

Outlets should be at least 40 cm (16 inches) from the floor. When they are needed near a work surface they should be 1.15 m. (42 inches) from the floor.

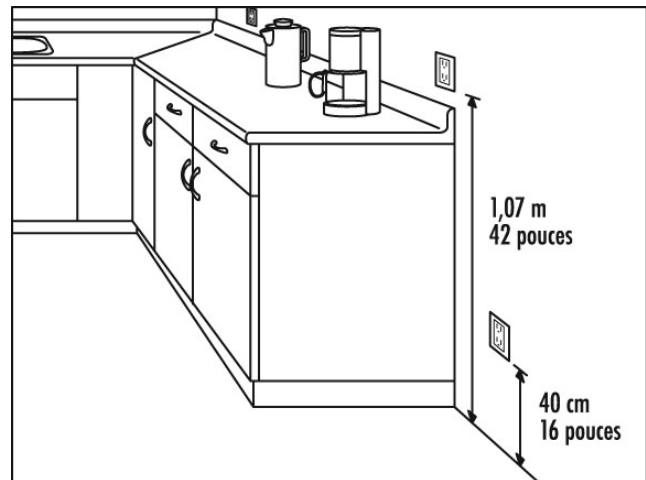

42 inches

16 inches



### Caution!

#### Refer to occupational therapist if:

- Persons with severe cognitive disorders are not, in principle, eligible for this program. Other safety provisions may be necessary in the kitchen.



## KITCHEN

## Accessible electrical outlets

---

### Installation

Electrical equipment should be installed by an electrician. Outlets should be at least 40 cm (16 inches when installed) from the floor. When they are needed near a work surface they should be 1.15 m. (42 inches) from the floor.

### Suppliers

Electricians (yellow pages of the phonebook).

Approximate cost: installation \$\$\$\$



### Tips

- Avoid using extension cords. When unplugging an appliance, do not pull on the cord, make a habit of taking hold of the plug. Moreover, if the work surface is adequate, some appliances such as coffee makers and toasters can be left plugged in.





## KITCHEN

## Solid tables and chairs

### Function

Tables and chairs are often used to lean on when a person is getting up, sitting down or moving around. They should therefore be stable and solid in order to give good support.

### Description

When changing from a sitting to a standing position or the reverse, the person should preferably use the arms of the chair for support. Chairs should be easy to slide and the person should be able to place their feet flat on the floor. In addition, the table should not move when the person uses it for support (ex.: to reach an object placed on the table) and it should be comfortable for eating (ex.: slightly higher than the elbows of the person seated at the table). It is recommended that tables and chairs that are not safe be replaced.

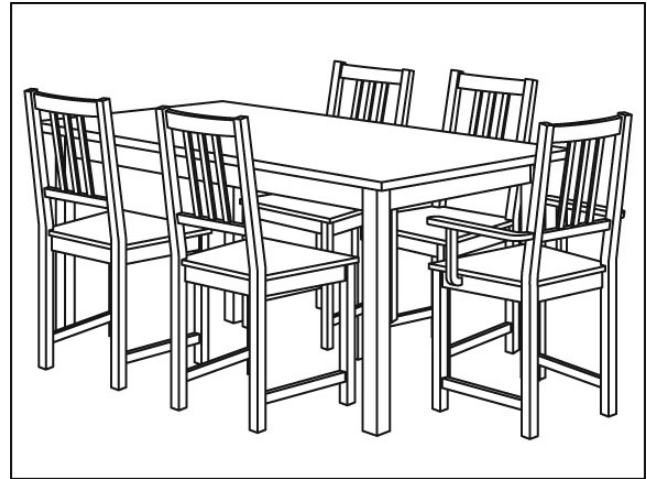

### Suppliers

Furniture stores or department stores.

Approximate cost: table and chairs: \$\$\$\$



### Caution!

#### Refer to occupational therapist if:

- The person has difficulty getting up from a chair or uses the furniture for support when moving around.



## KITCHEN

## Solid tables and chairs

---



### Tips

- To make it easier to get up, the person should sit on the edge of the chair, lean forward from the hips (shoulders almost above knees) and place feet close to the chair.



## KITCHEN

## Safe practices

---

- Do not wax the floor.
- Check once a month that the fire extinguisher and smoke detectors are working properly.
- Wipe up any spills immediately.
- Close all drawers and doors after use, to avoid banging into them.
- Use a trolley on wheels to carry heavy objects and reduce walking.
- Do not use a step stool to reach high places. Instead, move frequently-used items and increase accessible storage spaces, or ask for help if needed.
- If you use a step stool for some exceptional reason, avoid tilting your head back. This can cause a loss of balance without any warning sign. Never use a box or chair to climb.
- Sit at the table to prepare food, to avoid tiring yourself too quickly.
- Before leaning on a chair or table to get up or sit down, make sure that it is stable.
- Use a kettle that whistles or stops automatically when you want to boil water.
- Avoid lifting heavy objects or carrying packages that obstruct your view, as they could make you lose your balance.
- To avoid the danger of burns from hot water, install an anti-burn device (mixing faucet) on the kitchen tap.
- Use household aids to reduce bending.



## Section 5

### Living room

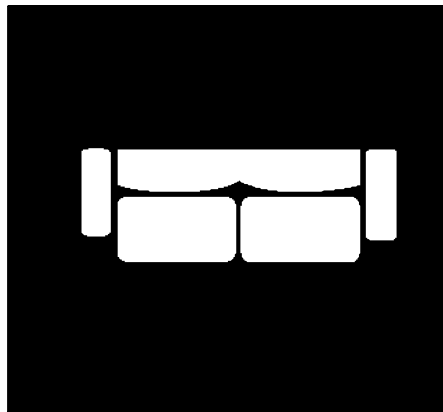

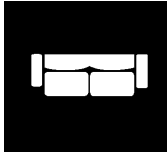

## LIVING ROOM

---

### Here are the points to consider:

Safe armchair

No low table in the middle of the living room

Safe practices

### Legend

\$: between \$5 and \$25

\$\$: between \$25 and \$50

\$\$\$: between \$50 and \$100

\$\$\$\$: more than \$100

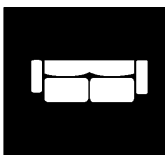

## LIVING ROOM

## Safe armchair

### Function

The armchair usually used by the person should be both comfortable and safe.

### Description

The criteria for a safe armchair are as follows: firm, stable, shallow, with armrests, and a floor-to-seat height of 45 to 55 cm (18 to 22 inches). It should be the right size, and enable the person to get up easily.

45 to 55 cm

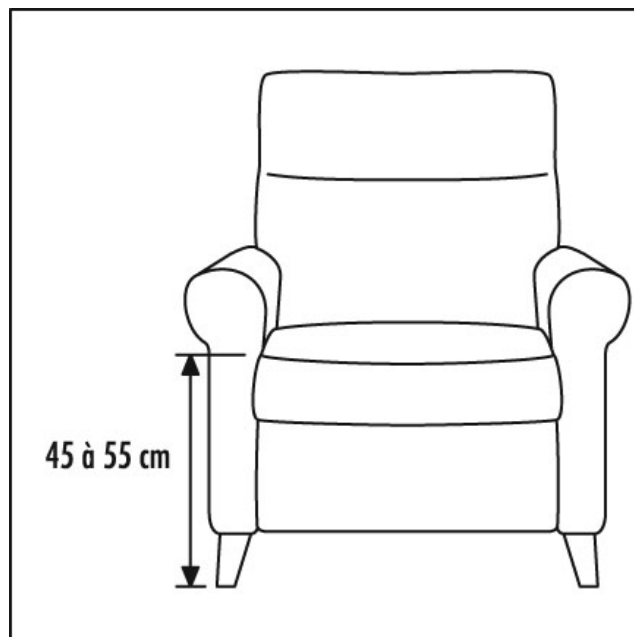

### Installation

If the armchair is too soft, it is possible to add a wooden board under the cushion. You can also find stable high-density cushions in orthopedic and medical centres or department stores. If the chair is too low, raise it on a wooden base (nailed wooden blocks). You should not raise the chair too high because the person should be able to put their feet flat on the floor when seated. Get rid of chairs that are too deep, especially ones that have no armrests.

### Suppliers

Approximate cost: depending on the wood chosen and the dimensions: \$\$\$\$

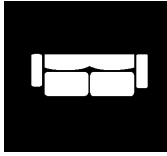

## LIVING ROOM

### Safe armchair

---



#### Caution!

Refer to occupational therapist if:

- The person has difficulty getting up.



#### Tips

- Avoid using a rocking chair, or equip it with a manual or automatic blocking system to prevent movement when the person is getting up or sitting down.
- Avoid using a footstool that can get in the way when the person is moving around. Opt for an armchair with a retractable footrest.



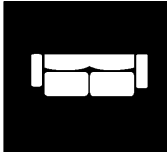

## LIVING ROOM

### No low tables in the living room

#### Function

A low table in the middle of the living room constitutes a hazard for falls. The person can easily forget it and trip over it, as it is not in their field of vision.

#### Description

It is advisable to remove low tables and any other piece of furniture that is in a walking area and outside of the person's visual field (close to the floor).

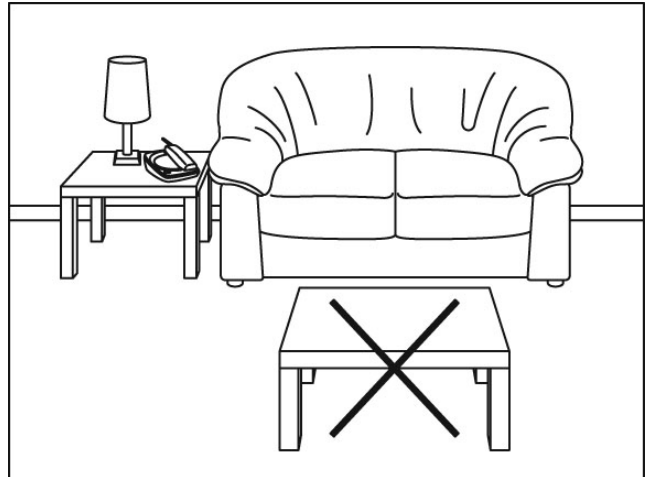

#### Caution!

Refer to occupational therapist if:

- The person has peripheral vision or visual field problems (see screening for visual disorders).



#### Tips

- Place a small table close to the sofa to hold things such as your telephone, remote control, drinking glasses, books, etc.). This table should be well away from walking areas.



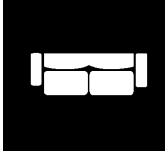

## LIVING ROOM

### Safe practices

---

- Do not leave things lying on the floor, to avoid tripping over them.
- Put newspapers in a magazine rack or a box rather than on the floor.
- Get up slowly from your armchair and pause for about two minutes in place before beginning to walk (particularly in the morning).
- Make sure that furniture and lamps are stable and well anchored.
- Arrange your furniture so that you can move around easily.



## Section 6

### Bedroom





## BEDROOM

---

### Here are the points to consider:

Correct bed height

Firm mattress

Telephone, lamp, luminous clock and flashlight on the bedside table near the bed

Accessible storage space

Safe practices

### Legend

\$: between \$5 and \$25

\$\$: between \$25 and \$50

\$\$\$: between \$50 and \$100

\$\$\$\$: more than \$100



## BEDROOM

## Correct bed height

### Function

**50 to 55 cm**

The bed should be suited to the person's height. If it is too low, changing from a seated to a standing position increases the risk of falling. A bed that is too high, i.e. that does not let the person put their feet flat on the floor, can also increase the risk of falling.

### Description

The bed should have a minimum height of 50 cm (18 inches) and a maximum height of 55 cm (22 inches). If the bed is too low, it is possible to raise it on small wooden blocks that are anti-skid or nailed. The centre of the blocks should be hollow in order to stabilize the legs of the bed. If the bed is too high, you can remove, modify or replace the legs.

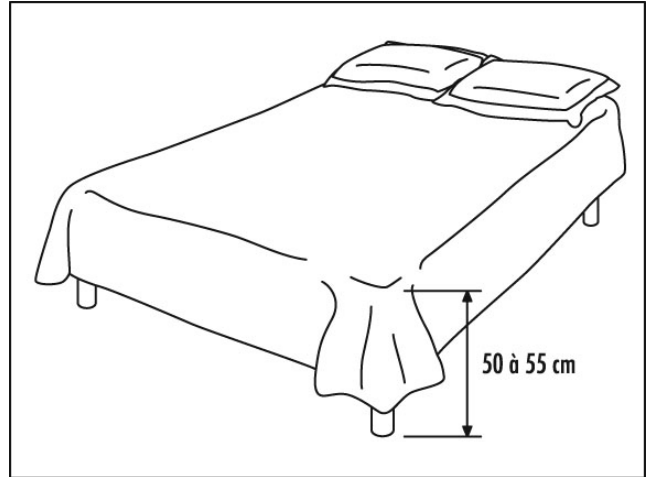

### Caution!

#### Refer to occupational therapist if:

- The person has difficulty getting up even though the bed is the correct height.

## Suppliers

Carpenter: \$\$/hour

Approximate cost of blocks: depends on the wood chosen and the height required. Available in specialized or furniture stores.



## BEDROOM

## Correct bed height

---



### Tips

- Get up slowly after you have been lying down.
- Avoid long bed covers that can get in your way when you move around.





## BEDROOM

## Firm mattress

### Function

A firm or orthopedic mattress allows the person to get up more easily from a lying position.

### Description

If the mattress is soft, change it or get a wooden board to put under it.

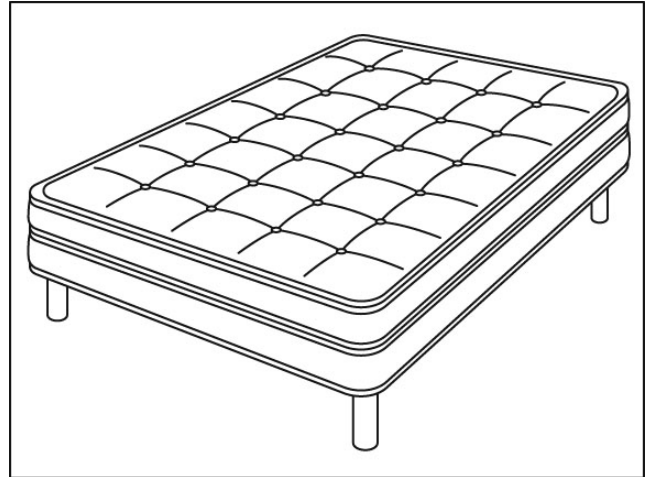

### Suppliers

Hardware stores, carpenters (yellow pages of phonebook).

Furniture stores, mattress stores.

Approximate cost: depending on the size and model: \$\$\$\$



### Tips

- Walkers should not be used to facilitate getting up. The person should push on the side of the bed with their hands and only grasp the walker when standing.





## BEDROOM

### Telephone, lamp, luminous clock and flashlight on the bedside table

#### Function

There should be a bedside table close to the head of the bed. The telephone should always be within reach. This reduces the need for walking and enables the person to contact someone for help in case of need.

#### Description

It is advisable to have a phone in every room, or to get a wireless phone and get into the habit of bringing it around with you. Other accessories are recommended for the bedside table: a touch-activated lamp, ideally with variable intensity. This avoids moving around in the dark and reduces the need for movement. A luminous clock avoids having to get up to see the time. A flashlight can be used for moving around during the night or during a power outage.

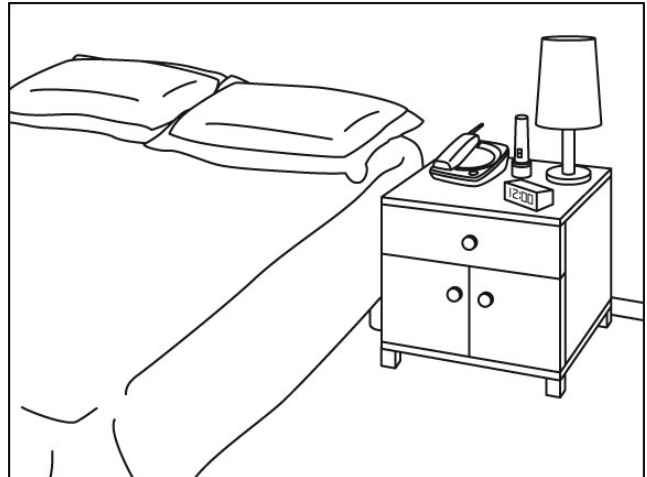

#### Suppliers

Department stores, specialized stores (lighting stores).

Regular or wireless telephone: department stores, boutiques specializing in electronics and phones.

Approximate cost: regular telephone: \$\$  
wireless phone: \$\$\$

Electricians (yellow pages of phonebook).

Approximate cost: Installation of a new telephone jack: \$\$\$\$



#### Tips

- If there is no phone jack in the bedroom, use a wireless phone and get into the habit of carrying it around with you.





## BEDROOM

## Accessible storage space

### Function

The rod and shelves should be placed so that the person does not have to stretch or climb to get their clothes.

### Description

Use a rack to raise commonly-used objects (ex.: shoes) from the floor. Lower rods or shelves to a functional height (between the person's knees and shoulders). Make shelves narrower or install them on rails. Check that the storage space is sufficient and that drawers open and close easily (weight and degree of friction).



### Caution!

#### Refer to occupational therapist if:

- Limited shoulder or hip movement prevents the person from using some of the storage spaces even when these are accessible.

## Suppliers

Carpenters (yellow pages of phonebook).

Approximate cost: Installation: \$\$/hour by a carpenter.



## BEDROOM

## Accessible storage space

---



### Tips

- Get in the habit of not leaving clothes on the floor.



## BEDROOM

## Safe practices

---

- Sit on a chair when getting dressed and putting on your shoes.
- Use dressing aids, for example: elastic laces, a long shoehorn.
- Always close drawers after use.
- Place night medication containers on the bedside table. However, medications should not be accessible to small children, so this is not recommended if there are children around.
- Keep a flashlight within reach in case of a power outage.
- Do not leave objects lying around on the floor.
- Do not get up too quickly when you have been lying down, as you could get dizzy and fall. Remain seated for a few minutes on the side of the bed.
- Put on your glasses and shoes before standing up.
- Keep access to wardrobes, windows and doors clear at all times.
- Have sufficient space to move around on both sides of the bed.





## Section 7

# Every Room





## EVERY ROOM

---

### Here are the points to consider:

- A chair for the person to sit on while getting dressed
- Reduced thresholds between rooms
- Non-slippery floor surface
- Non-reflecting floor surface and unpatterned carpet
- Even flooring and well secured floor covering
- Well attached telephone and electrical cords
- Clear walking spaces
- Adequate lighting
- Accessible light switches at the entrance to each room
- Night lights
- Accessible telephone
- Safe practices

### Legend

- \$: between \$5 and \$25
- \$\$: between \$25 and \$50
- \$\$\$: between \$50 and \$100
- \$\$\$\$: more than \$100



## EVERY ROOM

## A chair for the person to sit on while getting dressed

### Function

The safest position to get dressed and put on your shoes is seated.

### Description

A stable chair should be available in the bedroom, to enable the person to remain seated when getting dressed or undressed. A chair with armrests can help the person to get up, but may also make it awkward to get dressed.

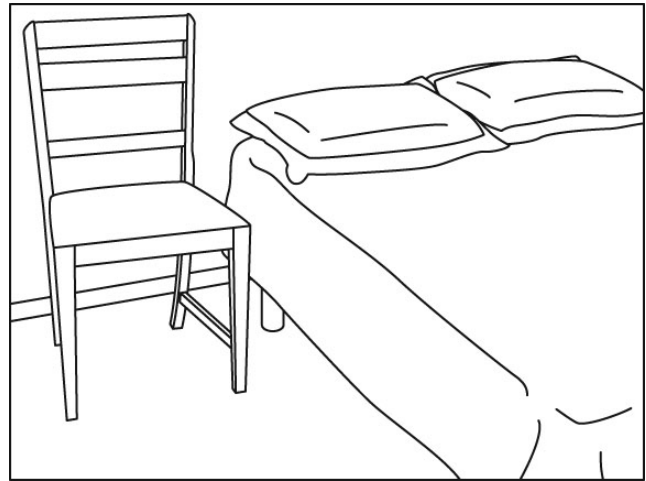

### Caution!

#### Refer to occupational therapist if:

- The person getting dressed sitting down has difficulty putting on certain clothes.

## Suppliers

Take a kitchen chair if the client has several.

Chairs can be bought in furniture stores.

Approximate cost: depending on the model selected: \$\$



## EVERY ROOM

## A chair for the person to sit on while getting dressed

---



### Tips

- Encourage using a chair rather than the side of the bed, even if the person's feet touch the floor; bed covers increase the risk of slipping or tripping.
- The chair should not become an obstacle. If it is impossible to put a chair in the bedroom due to lack of space, suggest that the person sit on the bed, on condition that the mattress is stable and feet touch the floor.



## EVERY ROOM

## Reduced thresholds between rooms

### Function

To ensure that the person does not trip going from one room to another.

### Description

If there is no difference in floor level between two rooms, the threshold should be removed (best solution). However, if the two floors are not on the same level, a tapered incline is recommended.

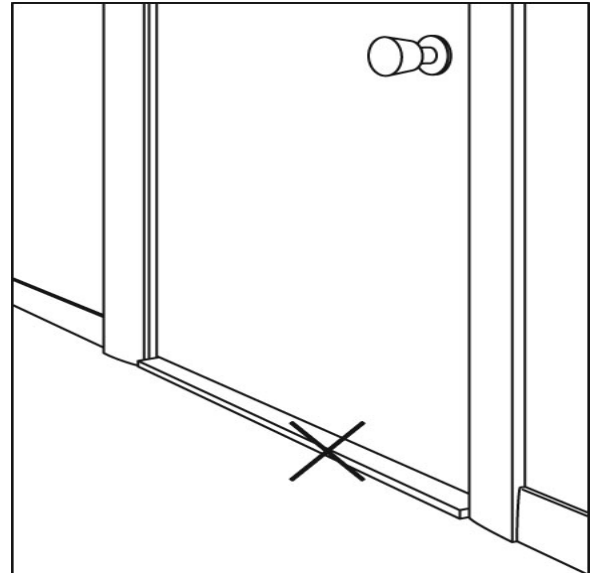

### Installation

If the threshold of the outside door has to be lowered or leveled, consult a carpenter to determine the best solution in the situation.

### Suppliers

Carpenters (yellow pages of phonebook).

Wood in hardware stores.

Approximate cost: carpenter \$\$/hour.



### Tips

- In a new building, or if the floor is being renovated, avoid any difference in floor levels between the rooms.





## EVERY ROOM

### Non-slippery floor surface

#### Function

To ensure that feet have a better grip.

#### Description

Do not wax the floor. Water, food or anything else on the floor can cause the person to slip.



#### Caution!

##### Refer to occupational therapist if:

- The person falls even though the floor is not slippery; they may need a walking aid.



#### Tips

- Clean up any spills immediately.







## EVERY ROOM

## Non-reflecting floor surface and unpatterned carpet

### Function

Reflections can create confusion and cause a loss of balance.

### Description

Avoid highly contrasting or accentuated motifs that give the impression of a change in floor level. Opt for textured floor surfaces that disperse the light and reduce glare. No-wax finishes (specialized product) can be used to reduce reflections. If the person wants to buy a carpet (rugs are not recommended) recommend a carpet that is unpatterned, antistatic, with a short tight weave, and easy to clean.

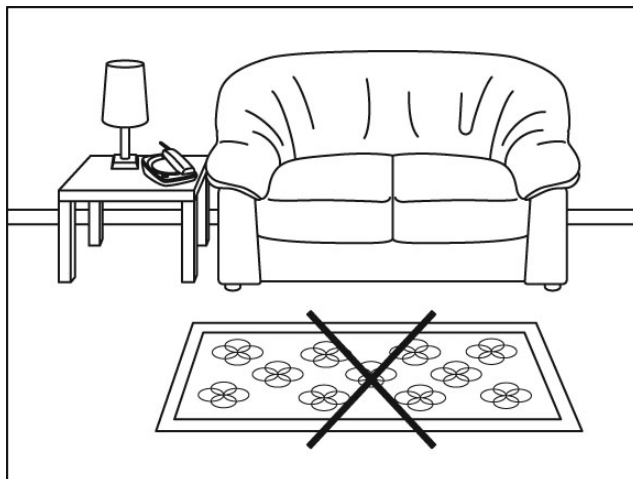

### Caution!

#### Refer to occupational therapist if:

- Despite the fact that the floor has no reflections, problems of visual perception cause falls (see visual disorders screening).

## Installation

To install new floor covering, it may be worthwhile to use the services of professionals who will guarantee their work.



## EVERY ROOM

**Non-reflecting floor surface and  
unpatterned carpet**

---

### Suppliers

Specialized store (floor covering) or hardware store.

Approximate cost: depends on the model selected.



#### Tips

- Remind the person of the importance of cleaning eyeglasses regularly.



## EVERY ROOM

## Even flooring and well-secured floor covering

### Function

To ensure that feet or walking aids do not catch in any irregularities in the floor and cause falls. Uneven flooring, thresholds and uneven stairs can cause instability of the feet and trigger a fall.

### Description

The floor should be as even as possible. Floor covering between two rooms should be well fastened down. Broken or raised up parts (ceramic tiles, wood, carpet) should be fastened down and repaired immediately. Remove all rugs or mats. They should not be used except when essential, for example when the person steps out of the bath or shower (it is then recommended that you remove the mat after use). In exceptional circumstances, rugs or mats may be left in place. A possible compromise would be to keep tight weave rugs and fasten them firmly to the floor using a double-sided adhesive tape or an anti-skid backing sewn under the rug.

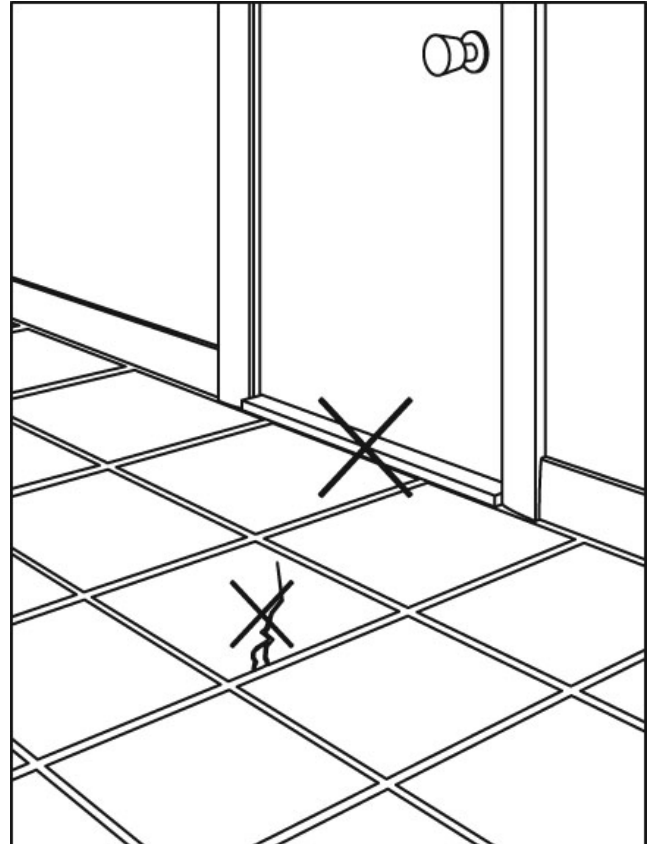

### Caution!

#### Refer to occupational therapist if:

- Despite the evenness of the floor the person's feet are unstable.



## EVERY ROOM

## Even flooring and well-secured floor covering

---

### Suppliers

Specialized stores (floor covering)

Carpenters (yellow pages of phonebook).

Glue to fasten down carpets and cushion floors can be found in hardware stores.

Approximate cost: depending on repairs made

glue: \$



### Tips

- All types of mats and rugs, even when well fastened down, are fall hazards. That is why it is preferable to remove them.
- Follow this advice even in less frequented places such as the basement.



## EVERY ROOM

## Well attached telephone and electrical cords

### Function

To clear walking spaces of any cords that could cause falls.

### Description

All cords should be attached to the wall with adhesive tape or clips.

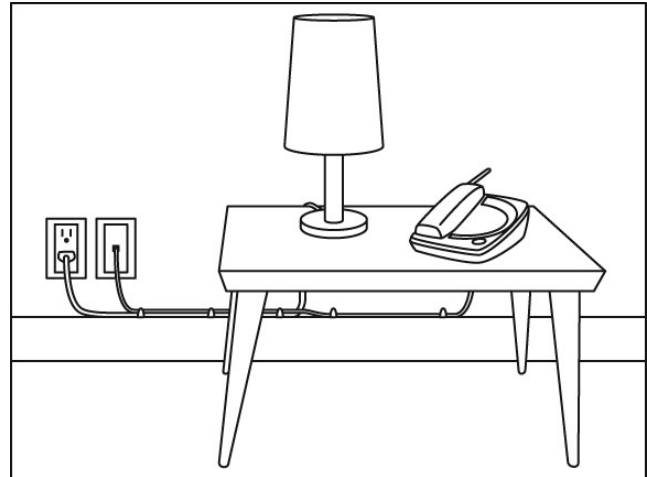

### Suppliers

Hardware, department stores.

Specialized electronics boutiques.

Approximate cost: adhesive tape: \$

Wireless telephone: \$\$\$



### Tips

- Depending on the circumstances, recommend that the person have either a telephone in each room or a wireless telephone. If the latter, the person should get into the habit of carrying it everywhere.
- Never run when the telephone rings. Tell relatives and friends to let it ring for a long time.
- A person who is in the habit of carrying the telephone from one room to the other cannot attach the cord to the wall. Suggest a wireless telephone.





## EVERY ROOM

### Clear walking spaces

#### Function

To ensure that the person can move around easily and safely inside the house, and to ensure access to windows, doors and wardrobes.

#### Description

Telephone and electrical cords should be well attached. In addition, nothing should be left lying on the floor. It is recommended that cords and wires be attached along the walls with adhesive tape or plastic clips and objects, including rugs or mats, be removed from walking spaces. Furniture and other objects should be distanced from walking spaces.

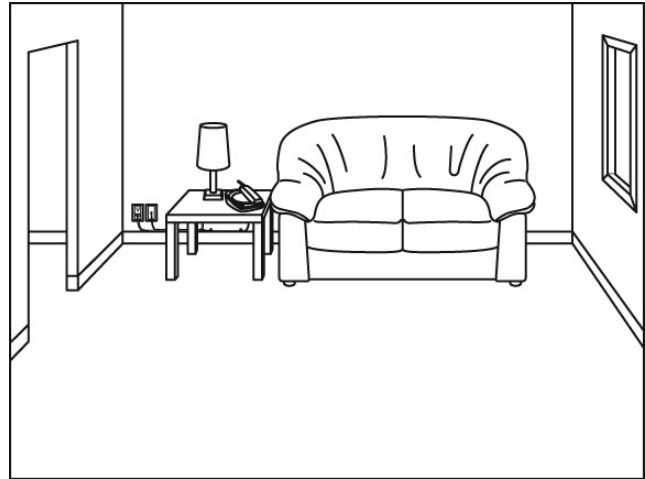

#### Caution!

##### Refer to occupational therapist if:

- Balance problems prevent the person from moving around safely.



#### Tip

- Explain to family and friends the importance of not leaving things on the floor or on the stairs.
- A person who is in the habit of carrying the telephone from one room to the other cannot attach the cord to the wall. Suggest a wireless telephone.







## EVERY ROOM

### Adequate lighting

#### Function

To ensure enough visibility to enable the person to move around safely.

#### Description

Lighting should be constant and sufficient in all rooms, hallways and stairs. Natural light is preferable (curtains that allow the light through) when possible. The light should carry to the whole room without creating shadowy areas and without causing glare. If necessary, increase the lighting by adding a lamp. Install a timer or an automatic dark detector (photosensitive) to create artificial lighting when needed.

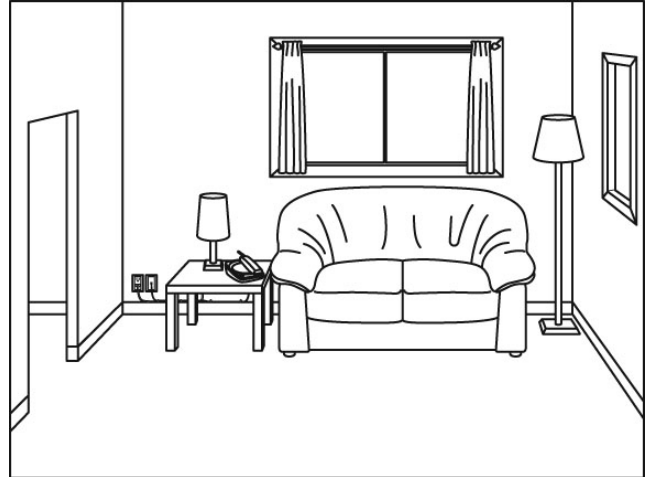

#### Caution!

#### Refer to occupational therapist if:

- Visual perception problems persist despite adequate lighting.



## EVERY ROOM

### Adequate lighting

---

#### Suppliers

Hardware stores.

Department and specialised (lighting) stores

Approximate cost: bulb: \$

table lamp: \$\$ depends on the model selected

Electricians (yellow pages of phonebook): depends on the installation



#### Tips

- Lighting is recommended in closets.
- Use artificial lighting on dark days. Before using a higher wattage bulb, check the maximum capacity authorized for the lamp model, in order to avoid fire hazards.



## EVERY ROOM

## Accessible light switches at the entrance to every room

### Function

To avoid walking around in the dark.

### Description

Light switches should be located at the entrance to every room; they should be accessible and at a functional height (between the person's waist and shoulders). Stairs and hallways should have a light switch at both ends.

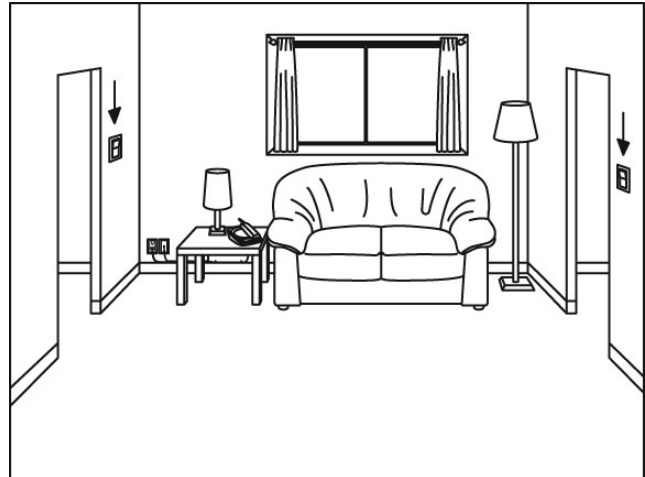

### Caution!

#### Refer to occupational therapist if:

- Despite accessible light switches placed at a functional height, limited shoulder reach restricts the person's ability to use them.

## Installation

It is recommended that you have an electrician install light switches.



## EVERY ROOM

## Accessible light switches at the entrance to every room

---

### Suppliers

Electricians (yellow pages of phonebook).

Approximate cost: depends on the amount of work.



### Tips

- Replace burnt or defective bulbs immediately.



## EVERY ROOM

### Night lights

#### Function

To produce a soft non-glaring light to help the eyes to adjust, while adequately lighting the floor. Night lights should be used in all walking spaces when the natural or artificial light is inadequate.

#### Description

A night light should be located at the base of the wall in hallways when the light (natural or artificial) is insufficient (especially between the bedroom and bathroom). Ideally, the night light should be equipped with a magic eye (automatic darkness detection sensor). This may also be a good idea in the bedroom and the bathroom.

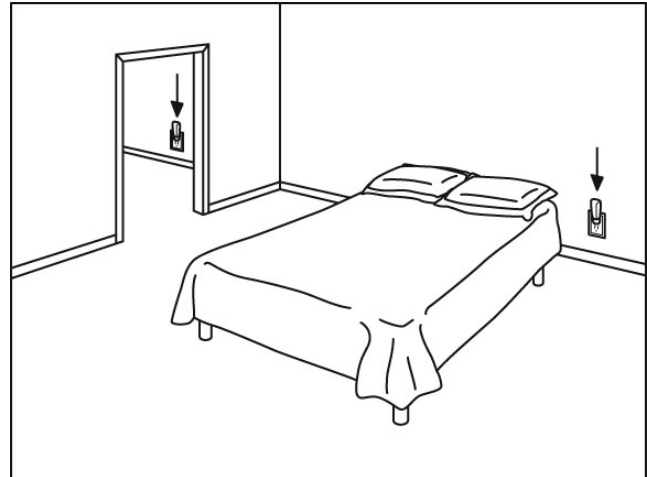

#### Caution!

##### Refer to occupational therapist if:

- The person has visual perception problems, and night lights appear to be insufficient.

### Installation

The services of an electrician will be needed if electrical outlets need to be installed.



## EVERY ROOM

## Night lights

---

### Suppliers

Department stores: \$

Electricians: yellow pages of phonebook.

Approximate cost: depends on the installation required.



### Tips

- Insist on the importance of night lights to light the floor even if another light (often exterior) lights the room.
- Change bulbs as soon as they burn out.
- Opt for models equipped with an automatic magic eye, which light up when the natural or artificial lighting is insufficient.



## EVERY ROOM

### Accessible telephone

#### Function

Having a telephone always within reach enables the person to call for help in an emergency. It also allows the person to answer the phone without having to hurry.

#### Description

It is advisable to have a telephone in every room, or to get a wireless phone and get into the habit of carrying it around. The phone should not be hung on the wall, as it would be out of reach if the person should fall. Phones should be near a chair to allow the person to sit down while talking on the phone.

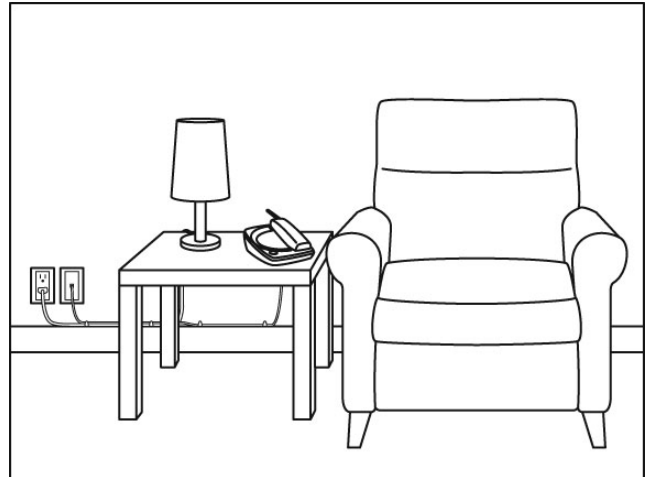

#### Caution!

##### Refer to occupational therapist if:

- The person has severe communication problems or is unable to dial numbers in an emergency.

## Suppliers

Department stores, boutiques specializing in electronics or telephones.

Approximate cost: standard telephone: \$\$

wireless phone: \$\$\$

installation of a new phone jack: \$\$\$\$



## EVERY ROOM

## Accessible telephone

---



### Tips

- A person living alone can get a home phone personal emergency response service.
- If each room does not have a phone jack, a wireless telephone will be fine (so long as the person gets into the habit of carrying it around, by fastening it to their belt, for example). The person could also have a regular phone in the most-frequently-used room and a wireless phone for use in the other rooms.
- Never run when the phone rings. Tell family and friends to let it ring for a long time.
- It is also possible to program emergency numbers.





## EVERY ROOM

---

### Safe practices

- Clean up all spills immediately.
- Close all drawers and doors after use.
- Keep interior doors wide open.
- Get up slowly from your armchair or bed and wait for a short time before starting to walk.
- Get as much natural light as you can (but without glare) by using see-through curtains.
- Turn on the lights on dark days.
- Have all damaged floor surfaces repaired immediately.
- Choose solid pieces of furniture to lean on.
- Avoid waxing furniture, covering them with table cloths or having them mounted on wheels.
- Make sure that the telephone is always within reach (use a wireless phone if you do not have a phone in each room).
- Keep a list of emergency numbers in large print (police, ambulance, firefighters, a person you trust) on the wall near the telephone.
- If you have a small pet in the house (usually outside your field of vision), a coloured collar (contrasting colour) or a little bell (noise) around its neck will help you to locate it as you move around.
- Put away clothes and covers that trail from the bed or chairs.
- Use a height-adjustable clothesline.
- Don't overtax yourself doing interior or exterior domestic tasks.



## EVERY ROOM

### Safe practices

---

- Make sure that you can see clearly and hear well (have your glasses changed and your hearing-aid checked regularly). It may also be useful to adjust the volume of your phone or to have a device for the hearing-impaired on your phone.
- Ask about possible side-effects of your medications, such as somnolence or dizziness that could cause falls.
- Be more vigilant when you take sedatives or sleeping pills.
- Have your medication checked regularly to ensure that it does not increase the risk of falling.
- Do not drink alcohol when taking medication.
- Do not take over-the-counter drugs or certain natural products without discussing it with your pharmacist or your physician.
- Do not hesitate to ask for help to get objects that are out of your reach.
- Use a cane with an ice pick for greater safety in winter.
- Be careful when walking outside (holes, ice in winter, ...).

## CLOTHING

- Do not wear long bathrobes that could cause you to trip.
- Do not wear clothes that are too wide, loose or long. You could get them caught in furniture or any other household accessory and lose your balance.
- Shoes should fit well and cover your heels (in general with laces or Velcro fastening); they should have low heels and non-slip or anti-skid soles.
- Avoid wearing soft slippery slippers, as they reduce the stability of your feet and thus increase the risk of falling. Choose slippers with an anti-skid sole.



